

PHOENIX 300

HIGH CAPACITY DEHUMIDIFIER

Therma-Stor Products

A Division of DEC International
Box 8050 Madison, WI 53708

Toll Free 1-800-533-7533

Local 1-608-222-5301



PHOENIX 300 Operation & Service Instructions

Table of Contents

1. Specifications.....	1
2. Operation.....	1
2.1 Transporting the Phoenix 300.....	1
2.2 Location.....	1
2.3 Electrical Requirements.....	2
2.4 Condensate Removal.....	2
2.5 Ducting.....	2
2.6 Power Switch.....	2
2.7 Pump Purge Switch.....	2
2.8 Pump Fail Light.....	2
2.9 Hour Meter.....	2
2.10 Defrost Control Adjustment.....	2
2.11 Low Pressure Control.....	3
3. Maintenance.....	3
3.1 Air Filter.....	3
3.2 Blower Oiling.....	3
3.3 Storage.....	3
4. Service.....	4
4.1 Warranty.....	4
4.2 Technical description.....	4
4.3 Troubleshooting.....	4
4.4 Refrigerant Charging.....	5
4.5 Blower Replacement.....	5
4.6 Compressor/Capacitor Replacement.....	5
4.6A Checking Compressor Motor Circuits.....	5
4.6B Replacing a Burned Out Compressor.....	6
4.6C Replacing a Compressor- Non-Burn Out.....	7
4.7 Defrost Thermostat & Timer.....	7
4.8 Condensate Pump.....	7
4.9 Relay.....	7
4.10 Time Delay.....	7
5. Wiring Diagram.....	8
6. Service Parts List.....	9

Read the operation and maintenance instructions carefully **before** using this unit. Proper adherence to these instructions is essential to obtain maximum benefit from your Phoenix 300 dehumidifier.

1 Specifications

Model: PHOENIX 300 Dehumidifier
Electrical: 110-120 Vac, 12 Amps, grounded
Capacity: 176 pints per day @ 80°F, 60% RH
Operating Temp. Range: 33°F min., 105°F max.
Air Flow: 540 CFM without external ducting
Refrigerant Charge: 2 lbs., 5 oz. R-22
Optional Duct connection: 10" round outlet
Size: 45" high x 24" wide x 20" deep cabinet
46" high x 29" wide x 25" deep overall
Weight: 175 lbs.

2 Operation

2.1 Transporting the Phoenix

The Phoenix 300 must always be upright when transported by vehicle. It may be tipped on to its handle and back for loading and moving by hand.

2.2 Location

Note the following precautions when locating the Phoenix 300:

- It is designed to be used **INDOORS ONLY**.
- If used in a wet area, plug it into a **GROUND FAULT INTERRUPTER**.
- **DO NOT** use the Phoenix 300 as a bench or table.
- It must always be used in the upright position.
- The air inlet on top & the side outlet must be at least 1 foot from walls and other obstructions to air flow.
- If the humid area is very large, dehumidification can be improved by adding an outlet duct to circulate air to stagnant areas (see Sec. 2.5).

Serial No. _____

Purchase Date _____

Dealer's Name _____

2.3 Electrical Requirements

The Phoenix 300 can be plugged into a grounded 15 Amp circuit. At 80°F, 60% RH, it draws 11.4 Amps. Due to the high percentage of a 15 Amp circuit's capacity that the unit uses, the circuit should be dedicated to running it only. Amp draw decreases at lower loads and increases at higher loads. At extremely high loads, a 20 Amp circuit may be required.

The unit briefly draws more amps to start if it has been stored in a cold area. This may cause a 15 Amp circuit breaker to trip. A 20 Amp circuit is recommended in such situations. Some models have a time delay to delay the compressor start about 2 minutes after the power switch is turned on. This reduces the unit's starting amp draw by starting the blower and compressor at different times.

If an extension cord is required, it must have a minimum of 12 gauge conductors if 25 feet long or less and 10 gauge conductors if greater than 25 feet long.

2.4 Condensate Removal

The Phoenix 300 is equipped with an internal condensate pump to remove the water that is condensed during dehumidification. This allows the condensate to be pumped 30' with the attached hose. If the condensate must be pumped more than 20 feet above the unit, a second pump must be added to relay the condensate.

2.5 Ducting

A detachable 10" round exhaust collar is supplied that will allow a 10" round flexible duct to be attached to the Phoenix 300 outlet. The duct and collar may be quickly attached to the Phoenix 300 by sliding the 4 collar tabs into the slots around the blower outlet and rotating the collar clockwise. It may be quickly removed to transport the unit more easily.

2.6 Power Switch

The power switch (on left side of hour meter) lights up when the unit is turned on. The unit will continue to run in all conditions until the switch is turned off; there is no dehumidistat.

2.7 Pump Purge Switch

This switch (on right side of hour meter) minimizes the water left in the condensate pump reservoir for moving or storage. Pressing and holding the pump purge switch will cause the condensate pump to run. Hold the switch in until the flow from the condensate hose stops.

2.8 Pump Fail Light

If the condensate pump fails, water draining into the pump reservoir will fill above its normal level. A safety float switch will then turn on the pump fail light (located next to the pump purge switch) and stop the compressor. This prevents water from overflowing and wetting the floor. The safety switch will not allow the compressor to restart until water has been removed from the pump reservoir.

2.9 Hour Meter

The digital hour meter measures the cumulative time that the unit is turned on to tenths of an hour. It stores its total when the unit is unplugged; the previous total will be displayed when the unit is next turned on. It resets to zero after 99,999.9 hours of operation.

2.10 Defrost Control Adjustment

When the Phoenix 300 is used in a cool area, frost will form on the cooling coil as it dehumidifies. When enough frost forms, the defrost thermostat will initiate the timed defrost cycle. The cycle periodically turns off the compressor while allowing the blower to run. The frost is melted by the air that the blower draws through the cooling coil.

The defrost cycle is automatic and designed for optimum performance above 50°F. If the unit is used in an area that is below 50°F for more than 2 hours, adjustment of the defrost timer is recommended to improve performance (see Sec. 2.10).

DRYING TIP: Air's ability to absorb moisture from wet surroundings and the Phoenix 300's ability to remove moisture from that air is greatly improved at higher temperatures. We recommend that the area to be dried be heated to over 70°F if possible. Less drying time will be required and efficiency will improve.

To adjust the defrost timer:

1. Unplug the unit.
2. Remove the front cover (6 screws).
3. The timer is fastened to the right inside panel. Every fourth peg around the dial is pushed out from the dial center except one section with 5 pegs out in a row. See figure 1. Each fourth "out" peg represents 15 minutes of compressor "off" time during every hour that the unit is in the defrost cycle.
4. To improve performance below 50°F, the compressor "off" time must be increased to 30 minutes per hour to allow the frost to completely melt. To do this, push the pegs out from the dial

center so that the pegs alternate with 2 toward the center, then 2 out from the center, all the way around the dial except for the section now with 6 pegs out in a row (see Fig. 1).

5. Replace the cover.

Change the timer pegs back to the original pattern for use above 50°F.

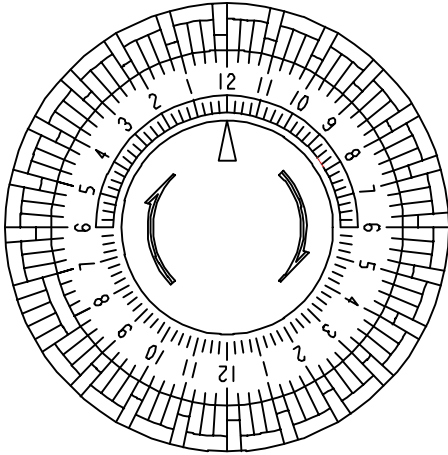

Above 50°

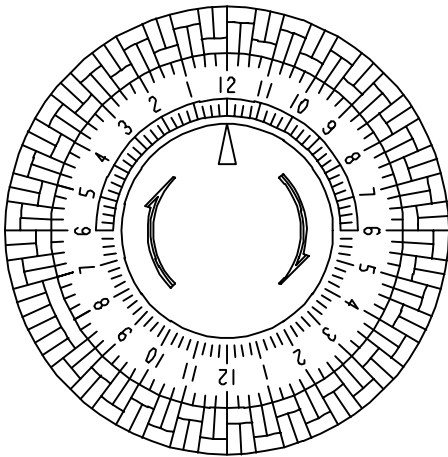

Below 50°

Figure 1: Defrost Control Timer

2.10 Low Pressure Control

If the low side refrigerant pressure drops to 15 PSIG, the low pressure control opens and shuts off the compressor and blower. It is an automatically reset control. Its primary function is to prevent damage to the compressor if a leak develops in the refrigeration system. It may also open if the unit is A) used in a cool area (below 50°F) and the defrost timer is not adjusted (see Sec. 2.10) or B) stored where it is below 40°F and then started. Under these conditions, the unit will restart within several minutes. Until the unit warms up, it may cycle several times.

3 Maintenance

3.1 Air Filter

The Phoenix 300 is equipped with a 4" thick, 35% efficient pleated fabric air filter that must be checked regularly. Operating the unit with a dirty filter will reduce the dehumidifier's capacity and efficiency and may cause the compressor to cycle off and on unnecessarily on the defrost control.

Two optional filters are available: A) a 2" pleated filter that has the same efficiency as the 4" standard filter, but less surface area. This filter would need to be changed more often than the 2" version. B) a 95% efficient 4" filter that acts as an air scrubber to catch mold and mildew spores.

The filter can generally be vacuumed clean several times before needing replacement. Replacement filters can be ordered from the factory or purchased locally if available. **DO NOT** operate the unit without the filter or with a less effective filter as the heat exchange coils inside the unit could become clogged and require disassembly to clean.

3.2 Blower Oiling

The blower motor is lubricated for life from the factory and does not require oiling by the owner.

3.3 Storage

There are two issues to consider when the Phoenix 300 is stored between uses and both pertain to the water trapped in the unit: damage caused by freezing and biological growth. The effect of the trapped water can be greatly reduced if precautions are taken to remove as much as possible before storage.

1. Use the pump purge switch (see Sec. 2.7 & Fig. 4) to reduce the water level in the reservoir.
2. Stretch the hose flat to drain it completely.

If the unit will not be exposed to freezing temperatures, an alternative way to reduce biological growth is to flush the unit with a bio-fungicide that is approved for use with copper, aluminum and polyethylene. To flush:

1. Run the hose to a drain.
2. Plug in the unit but do not turn it on.
3. Remove the air filter. Slowly pour a quart of the chemical through the top grille so that it drains into the white plastic slots.
4. Hold in the pump purge switch to reduce the water level in the reservoir.

4 Service

CAUTION: Servicing the Phoenix 300 with its **high pressure** refrigerant system and **high voltage** circuitry presents a health hazard that could result in **death**, serious bodily **injury**, and/or **property damage**. Only qualified service people should service this unit.

4.1 Warranty

A warranty certificate has been enclosed with this unit; read it before any repair is initiated.

If a warranty repair is required, call the factory first at 1-800-533-7533 for warranty claim authorization and technical assistance.

4.2 Technical Description

The PHOENIX 300 uses a refrigeration system similar to an air conditioner's to remove heat and moisture from incoming air, and to add heat to the air that is discharged (see Fig. 2).

Hot, high pressure refrigerant gas is routed from the compressor to the condenser coil (see Figure 2). The refrigerant is cooled and condensed by giving up its heat to the air that is about to be discharged from the unit. The refrigerant liquid then passes through a filter/drier and capillary tubing which cause the refrigerant pressure and temperature to drop. It next enters the evaporator coil where it absorbs heat from the incoming air and evaporates.

The evaporator operates in a flooded condition, which means that all the evaporator tubes contain liquid refrigerant during normal operation. A flooded evaporator should maintain constant pressure and temperature across the entire coil, from inlet to outlet. The mixture of gas and liquid refrigerant enter the accumulator after leaving the evaporator coil. The accumulator prevents any liquid refrigerant from reaching the compressor. The compressor evacuates the cool refrigerant gas from the accumulator and compresses it to a high pressure and temperature to repeat the process.

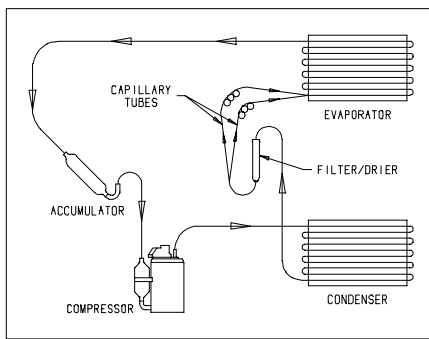

Figure 2: Refrigeration system of Phoenix

4.3 Troubleshooting

No dehumidification. Neither blower or compressor run. Power switch does not light when ON.

1. Unit unplugged or no power to outlet.
2. Power switch defective (Sec. 2.6).
3. Loose connection in internal wiring (Fig. 3).

No dehumidification. Neither blower or compressor run. Power switch ON & lit.

1. Low pressure control open (Sec. 2.11).
2. Power switch defective (Sec. 2.6).
3. Loose connection in internal wiring (Fig. 3).

Some dehumidification, blower runs continuously but compressor only runs sporadically.

1. Unit is in defrost cycle (Sec. 2.10 & 4.7).
2. Defrost thermostat defective or loose (Sec. 2.10 & 4.7).
3. Loose connection in compressor circuit (see Fig. 3).
4. Defective compressor overload (Sec. 4.6A).
5. Defective compressor (Sec. 4.6).
6. Defective relay (Sec. 4.9).
7. Defective time delay (Sec. 4.10).

No dehumidification. Blower runs but compressor does not. Pump fail light not lit.

1. Bad connection in compressor circuit (Fig. 3).
2. Defective compressor capacitor (Sec. 4.6A).
3. Defective compressor overload (Sec. 4.6A).
4. Defective compressor (Sec. 4.6).
5. Defective relay (Sec. 4.9).
6. Defective time delay (Sec. 4.10).

No dehumidification. Pump Fail Light lit. Blower runs but not compressor.

1. Bad connection in pump circuit (Fig. 3).
2. Pump float switch or safety switch defective (Sec. 4.8).
3. Pump motor defective (Sec. 4.8).

Blower does not run. Compressor runs briefly but cycles on & off.

1. Loose connection in blower circuit (Fig. 3).
2. Obstruction prevents impeller rotation.
3. Defective blower (Sec. 4.5).

Unit removes some water but not as much as expected.

1. Air temperature and/or humidity have dropped.
2. Humidity meter and/or thermometer used are out of calibration.
3. Unit has entered defrost cycle (Sec. 2.10 & 4.7).
4. Air filter dirty (Sec. 3.1).
5. Defrost timer incorrectly set for conditions (Sec. 2.10 & 4.7).
6. Defective defrost thermostat (Sec. 4.7)
7. Low refrigerant charge (Sec. 4.4).
8. Air leak such as loose cover.
9. Defective compressor (Sec. 4.6).
10. Restrictive exhaust ducting (Sec. 2.5)

Unit runs but does not pump water.

1. Hose kinked or plugged.
2. Pump check valve plugged (Sec. 4.8).
3. Bad connection in pump circuit (Fig. 3).
4. Hose disconnected internally.

Unit pumps water automatically but not when purge switch is pushed.

1. Bad connection in purge switch circuit (Fig. 3).
2. Defective purge switch (Sec. 2.7).

Evaporator coil frosted continuously, low dehumidifying capacity.

1. Defrost thermostat loose or defective (Sec. 2.10 & 4.7).
2. Defrost timer incorrectly set or defective (Sec. 2.10 & 4.7).
2. Low refrigerant charge (Sec. 4.4).
3. Dirty air filter or air flow restricted. (Sec. 3.1).

Compressor runs with power switch OFF.

1. Defective relay (Sec. 4.10).
2. Defective power switch (Sec. 2.6)

4.4 Refrigerant Charging

If the refrigerant charge is lost, a new charge must be accurately weighed in. If any of the old charge is left in the system, it must be removed before weighing in the new charge. Refer to the unit nameplate for the correct charge weight and refrigerant type.

4.5 Blower Replacement

The centrifugal blower has a PSC motor and internal thermal overload protection. If defective, the complete assembly must be replaced.

1. Unplug the power cord.
2. Remove the cabinet front (6 screws).
3. Disconnect the blower leads.
4. Pull the oil tubes out of the motor.
5. Tip the unit on its back. From the bottom, remove the 2 screws that fasten the blower housing to the base.
6. Remove the four screws holding the blower outlet flange to the cabinet end.
7. Remove the blower. Use care to avoid hooking wiring, tubing or electrical components.
8. Reassembling with the new blower is the above procedure reversed.

4.6 Compressor/Capacitor Replacement

This compressor is equipped with a two terminal external overload, run capacitor, but no start capacitor or relay (see Fig. 3).

CAUTION-ELECTRICAL SHOCK HAZARD: Electrical power must be present to perform some tests; these tests should be performed by a qualified service person.

4.6A Checking Compressor Motor Circuits

Perform the following tests if the blower runs but the compressor does not with the power switch ON.

1. Turn the power switch OFF and unplug the unit, remove the cabinet front (6 screws).
2. Plug in the unit and turn the power switch ON. Use a voltmeter to check for 110 to 120 volts between (a) the relay terminal that the black wire from the compressor connects to and (b) the capacitor terminal with the (3) white wires & (1) red wire connected. If voltage is present, go to step 3. If no voltage, the low pressure control, the time delay or the relay are open or there is a loose connection in the compressor circuit. Test each component for continuity; see the appropriate section if a defect is suspected.
3. Turn the power switch OFF and unplug the unit, then disconnect the red and yellow wires from compressor terminals R & S. Using an ohmmeter, check continuity between the points listed below.

4. Compressor terminals C and S: No continuity indicates an open start winding; the compressor must be replaced.
5. Compressor terminals C and R: No continuity indicates an open run winding; the compressor must be replaced.
6. Compressor terminal C and overload terminal 1: No continuity indicates a defective overload lead.
7. Overload terminals 1 and 3: If there is no continuity, the overload may be tripped; wait 10 minutes and try again. If there is still no continuity, it is defective and must be replaced.
8. Compressor terminal C and compressor case: Continuity indicates a grounded motor; the compressor must be replaced.
9. Disconnect the wires from the capacitor. Set the ohmmeter to the Rx1 scale; the capacitor is shorted and must be replaced if continuity exists across its terminals. If there is no needle movement with the meter set on the Rx100000 scale, the capacitor is open and must be replaced.
10. Reconnect the wires to the compressor and capacitor; plug in and turn on the unit. If the compressor fails to start, replace the run capacitor.
11. If the unit still does not start, adding a hard-start kit will provide greater starting torque. If this does not work, the compressor has an internal mechanical defect and must be replaced.

4.6B Replacing a Burned Out Compressor

The refrigerant and oil mixture in a compressor is chemically very stable under normal operating conditions. However, when an electrical short occurs in the compressor motor, the resulting high temperature arc causes a portion of the refrigerant oil mixture to break down into carbonaceous sludge, a very corrosive acid, and water. These contaminants must be carefully removed otherwise even small residues will attack replacement compressor motors and cause failures.

The following procedure is effective only if the system is monitored after replacing the compressor to insure that the clean up was complete.

1. This procedure assumes that the previously listed compressor motor circuit tests revealed a shorted or open winding. If so, cautiously smell the refrigerant from the compressor service port for the acid odor of a burn out. **WARNING:** The gas

could be toxic and highly acidic. If no acid odor is present, skip down to the section on changing a non-burn out compressor.

2. Remove and properly dispose of the system charge. **DO NOT** vent the refrigerant or allow it to contact your eyes or skin.
3. Remove the burned out compressor. Use rubber gloves if there is any possibility of coming in contact with the oil or sludge.
4. To facilitate subsequent steps, determine the type of burn out that occurred. If the discharge line shows no evidence of sludge and the suction line is also clean or perhaps has some light carbon deposits, the burn out occurred while the compressor was not rotating. Contaminants are therefore largely confined to the compressor housing. A single installation of liquid and suction line filter/driers will probably clean up the system.

If sludge is evident in the discharge line, it will likely be found in the suction line; this indicates the compressor burned out while running. Sludge and acid have been pumped throughout the system. Several changes of the liquid and suction filter/driers will probably be necessary to cleanse the system.

- 5) Correct the system fault that caused the burn out. Consult the factory for advice.
- 6) Install the replacement compressor with a new capacitor and an oversized liquid line filter.

In a running burn out, install an oversized suction line filter/drier between the accumulator and compressor. Thoroughly flush the accumulator with refrigerant to remove all trapped sludge and to prevent the oil hole from becoming plugged. A standing burn out does not require a suction line filter/drier.

- 7) Evacuate the system with a good vacuum pump and accurate vacuum gauge. Leave the pump on the system for at least an hour.
- 8) Operate the system for a short period of time, monitoring the suction pressure to determine that the suction filter is not becoming plugged. Replace the suction filter/drier if pressure drop occurs. If a severe running burn out has occurred, several filter/driers may have to be replaced to remove all of the acid and moisture.

NOTE: NEVER use the compressor to evacuate the system or any part of it.

4.6C Replacing a Compressor- Non-Burn Out

Remove the refrigerant from the system. Replace the compressor and liquid line filter/drier. Charge the system to 50 PSIG and check for leaks. Remove the charge and weigh in the refrigerant quantity listed on the nameplate. Operate the system to verify performance.

4.7 Defrost Thermostat & Timer

The defrost thermostat is attached to the refrigerant suction tube between the accumulator and compressor. If the low side refrigerant temperature drops due to excessive frost formation on the evaporator coil, the thermostat opens. The compressor is then cycled off and on by the defrost timer. The blower will continue to run, causing air to flow through the evaporator coil and melt the ice when the compressor is off. When the air temperature and/or humidity increase, the evaporator temperature will rise and the thermostat will close to end the defrost cycle.

To improve performance in low temperatures, see Sec. 2.9 for defrost timer adjustment.

4.8 Condensate Pump

Condensate is automatically pumped when the water level in the pump's reservoir rises to close the float switch or if the pump purge switch is held in.

If the pump is unable to empty its reservoir due to a pump failure or blocked condensate hose, a pump safety float switch is triggered before the reservoir overflows. The switch turns on the pump fail light & turns off the compressor via its relay.

To replace the condensate pump:

1. Unplug the unit & remove the front cover.
2. Disconnect the 2 hoses from the pump.
3. Cut the pump lead wires near the old pump.
4. Remove the 4 screws from the unit bottom that hold the pump to the base.
5. Attach the new pump with 4 screws.
6. Connect the new pump wiring. It may be easier to splice the new & old gray leads together with a wire nut, and splice the new & old yellow leads together, rather than route the new ones to the pump purge switch & pump fail light.
7. Connect the hoses to the new pump. Carefully route the hoses so they do not contact the copper refrigerant lines or the compressor shell.

4.9 Relay

The contacts of the single pole, single throw relay complete the power circuit to the compressor. The contacts are closed when power is provided to the relay coil via the control circuit. The control circuit includes the power switch, low pressure control, time delay (HP model), defrost thermostat and timer.

4.10 Time Delay (HP model only)

The HP model has a time delay relay in the compressor control circuit. This relay delays the compressor start about 2 minutes after the power switch is turned on. This reduces the unit's starting amp draw by starting the blower and compressor at different times. This reduces the chance of tripping a circuit breaker during hard start situations, such as when the unit has been stored in a cold place. It also reduces compressor short cycling after the compressor has stopped.

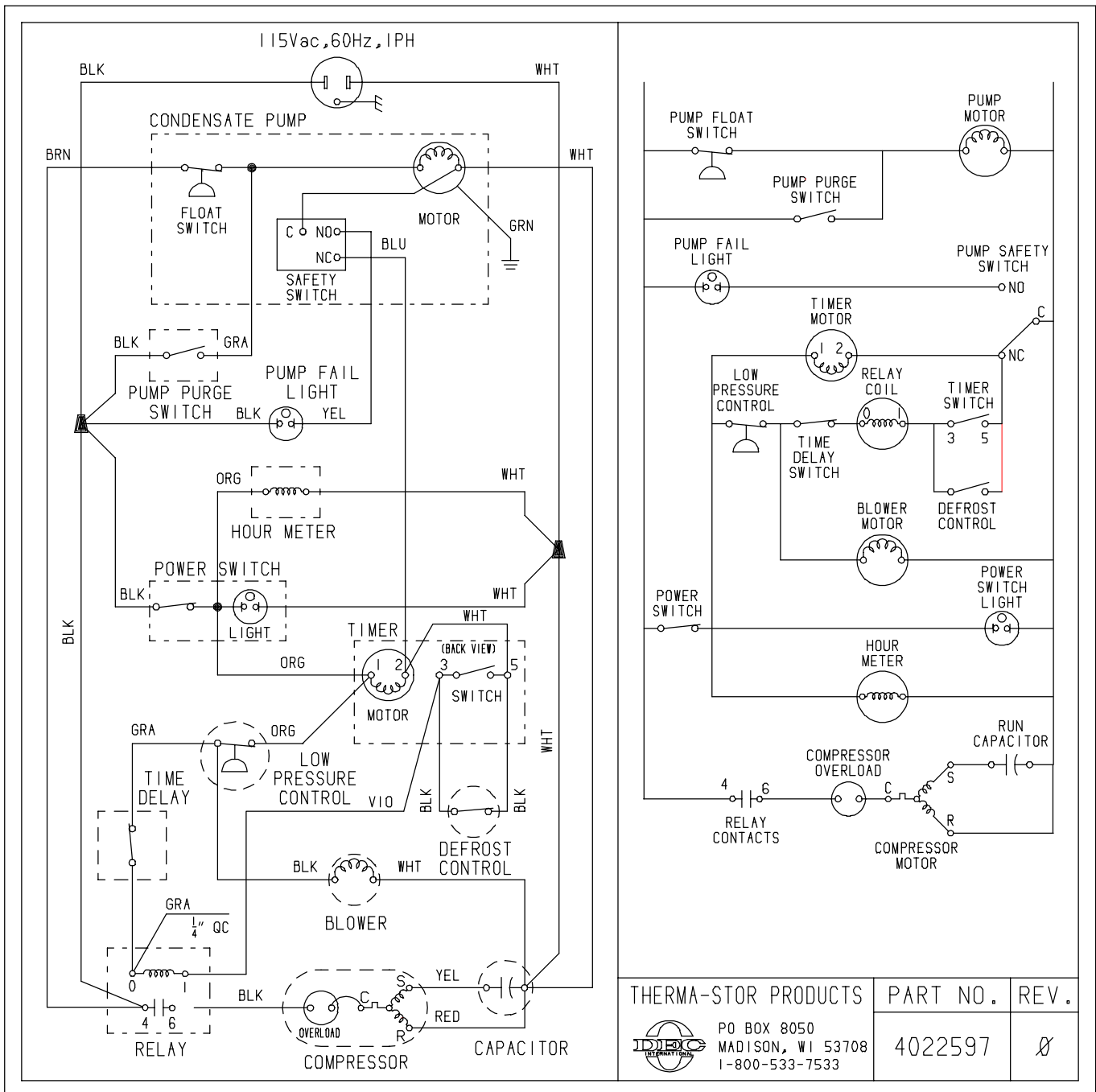

Figure 3: Electrical Schematic of Phoenix 300

SERVICE PARTS LIST: Phoenix 300 Dehumidifier

ITEM	PART NO.	QTY.	DESCRIPTION
1	4021818	1	Accumulator
2	4022636	1	Air Filter, Pleated, 2" x 20" x 20" (Grainger P/N 6B937)
	4022614	1	Air Filter, Pleated, 4" x 20" x 20" (Grainger P/N 2W236)
	4022624	1	Air Filter, Pleated, 4" x 20" x 20" (90-95% EFFICIENT)
3	4021083	1	Blower w/ Capacitor (Fasco 7074-2778)
4	4022622	2	Bumper, Foot, 1.50 Dia. x .75 High
5	4017777	2	Capillary Tubes, .059" ID x .124" OD x 32" long
6	4022563	1	Coil, Condenser
7	4022557	1	Coil, Evaporator
8	4022600	1	Compressor, Carlyle (P/N EBA135111A)(HP Model)
	4023645	1	Compressor, Carlyle (P/N EBA120111A)
9	4022595	1	Compressor Overload, Carlyle (included with compressor)
10	4022635	1	Condensate Pump
11	4022615	1	Cord & Wire Harness
12	4021908	1	Drain Hose (.38 ID x .56 OD x 33' long)
13	4022611	1	Outlet Collar (for Ducting Outlet)
14	4022593	1	Filter/Drier (not shown)
15	4021597	1	Hour Meter
16	4021089	1	Indicator Light, Red, 125V
17	4022616	1	Instruction Label (not shown)
18	4022219	1	Low Pressure Control (Ranco P/N 070-127000-D01)
19	1970010	1	Relay (Grainger P/N 4A711)
20	4022740	1	Run Capacitor, 30 MFD, 370V
21	4021997	6	Spring
22	4021796	1	Switch, Pump Purge
23	4021822	1	Switch, Power
24	4021470	1	Thermostat, Defrost
	4021648	1	Thermostat, Defrost, Mounting Clip
25	4021823	1	Timer, Defrost
26	4022878	1	Time Delay (HP Model)
27	4022613	2	Wheel, 12", Plastic
28	4022597	1	Wiring Diagram (on Cover)(not shown)
29	4021950	1	Ground Fault Interrupter (optional) (not shown)
30	4023079	1	Coupling, Body, Quick Connect, .38 Tube (not shown)
31	4023080	1	Coupling, Insert, Quick Connect, .38 Tube (not shown)

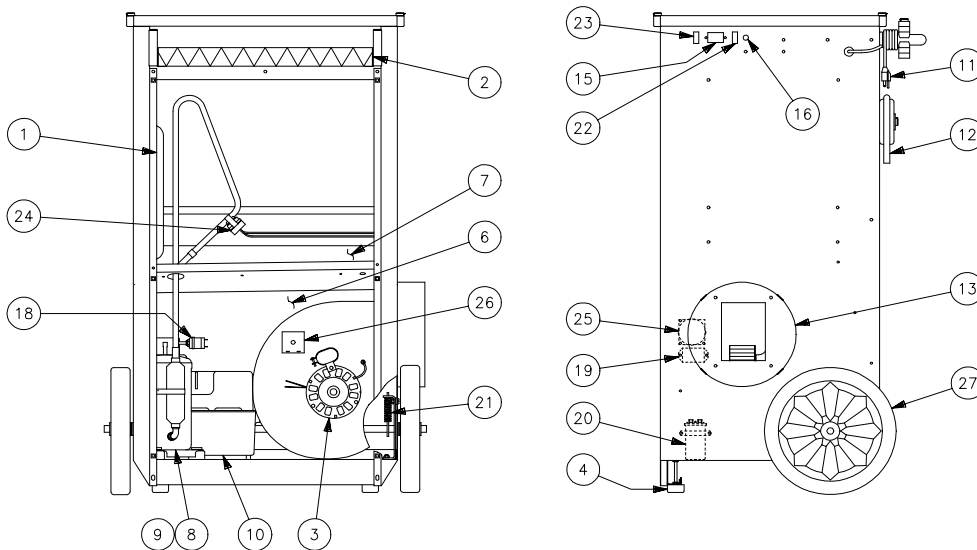

Figure 4