



Model A76 Dehumidifier Control

Installation & Operating Instructions



Installed by: _____

Installer phone: _____ Date installed: _____

OVERVIEW

The control allows the user to set and adjust the humidity setting and turn dehumidification on or off from a convenient location. In this application, the Model A76 uses an onboard sensor to monitor the relative humidity (%RH) in the space in which it is located and displays the measured relative humidity on the digital display.

READ AND SAVE THESE INSTRUCTIONS

TABLE OF CONTENTS

OVERVIEW	1
SAFETY INSTRUCTIONS	3
SPECIFICATIONS	3
LOCATION RECOMMENDATIONS	4
INSTALLATION	5
Mount Control	5
Wiring A76 with Dehumidifier Models A200V1, A300V1 and A300V3	6
Wiring A76 with Dehumidifier Models A70, A95, A95F, A130, A130F, A210V1, A320V1 and A320V3	7
SYSTEM CHECKOUT	9
Power Up	9
Test Mode	10
Humidity Setting	10
Offset	10
Turning On and Setting the Control	11
Sequence of Operation	11
TROUBLESHOOTING	12
Error Codes	12
Dehumidifier Diagnostic Codes	12
TABLE 1 – Troubleshooting Guide	13
TABLE 2 – Dehumidifier Diagnostic Codes	14
LIMITED WARRANTY	16

SAFETY INSTRUCTIONS

WARNING

1. Improper installation may cause property damage or injury. Installation, service, and maintenance must be performed by a qualified service technician.
2. Line voltage may cause serious injury from electric shock. Disconnect electrical power before starting installation or servicing. Leave power disconnected until installation/ service is completed. This control is not a 120 Volt (line voltage) device.

CAUTION

1. Read all instructions before beginning installation.
2. Do not use in pool applications. Pool chemicals can damage the control.
3. Do not use solvents or cleaners on or near the display and circuit board. Chemicals can damage components.

SPECIFICATIONS

ELECTRICAL

Input Voltage and Current	Voltage: 24VAC +/-20% Current: 25mA (nominal), 50mA (max.) at 24VAC
Output	Dry Contact, Normally Open

CONTROL

Control Range	35% – 80% RH
Accuracy	+/-5% RH
Differential	3%
Low Limit	40°F Dew Point
High Limit	99°F Dry Bulb

LOCATION RECOMMENDATIONS

MOUNT CONTROL

- In the area where moisture levels need to be monitored and controlled.
- On an interior wall.
- At/near canopy height.
- At least 18" from an outside wall.

DO NOT MOUNT CONTROL

- In the flow of a supply register.
- Behind doors, in corners or other dead air spaces.
- In direct sunlight, near lighting fixtures, or other appliances that give off heat.
- On an outside or unconditioned area wall.
- In stairwells or near outside doors.
- On a wall with concealed pipes or ductwork.

FIGURE 1 – MOUNTING LOCATION

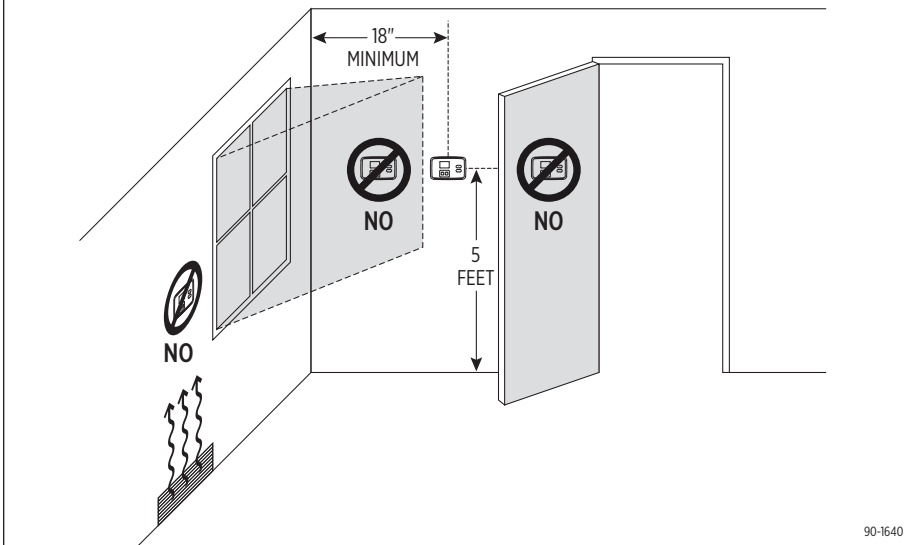

INSTALLATION

MOUNT CONTROL

FIGURE 2 – DISASSEMBLE CONTROL

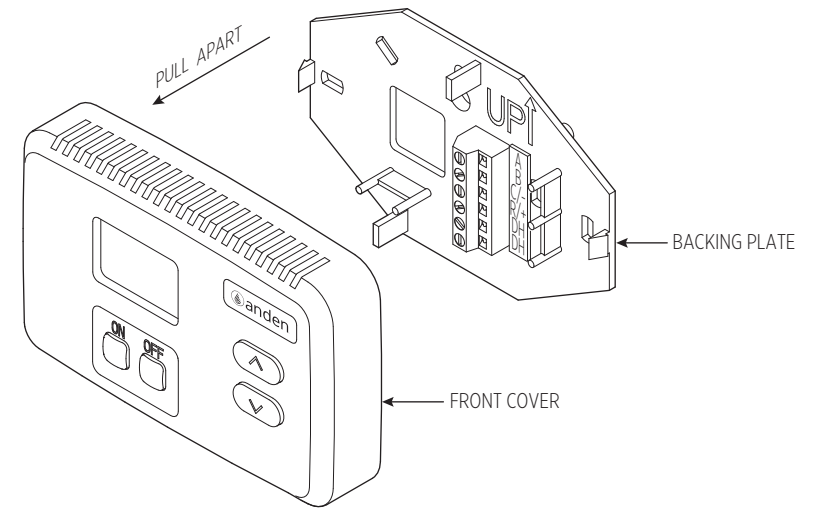
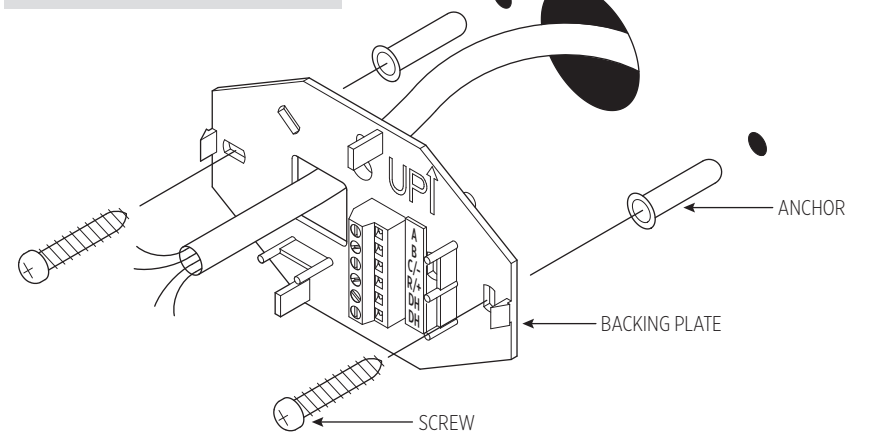

FIGURE 3 – MOUNT BACKING PLATE



REQUIRED COMPONENTS

18-22 gauge wire (field supplied), 4 wires required, run new cable as needed.

(2) #8 x 1-1/2" mounting screws (supplied)

(2) Anchors (supplied)

1. Level the backing plate on the wall and mark the mounting holes and wire access location on the wall.
2. Drill two 3/16" mounting holes and a 3/4" wire access hole. See **FIGURE 3**.
3. Install the drywall anchors flush with the wall surface. **NOTE:** Mounting holes on the backing plate are designed to fit on a horizontal J-box.
4. Run a 4-wire cable from the dehumidifier to the wall mount location and through the square hole in the backing plate.
5. Secure the backing plate to the wall using the two #8 x 1-1/2" screws.

WIRING A76 WITH DEHUMIDIFIER MODELS A200V1, A300V1 AND A300V3

NOTE: Use 18-22 AWG wire for control wiring.

A Model A76 Control must be wired to the dehumidifier for external control:

1. Turn off power to the dehumidifier at the fuse or breaker until wiring is completed.
2. Run a 3-wire thermostat cable (use 18-22 AWG wire) from the Model A76 to the electrical panel of the dehumidifier.
3. Trim about 1/4" of insulation from the end of the wires on each end. Insert a small blade screwdriver into the square opening next to the desired terminal in the dehumidifier to open the clamping spring of the terminal. Insert the wire and remove the screwdriver to catch the wire. At the Model A76 secure the wires into the terminals and tighten the cage screws. See **FIGURE 4**.
4. Use extra wire to make a small jumper to wire between the R/+ terminal and one of the DH terminals of the Model A76 Control.

The Model A76 will measure the relative humidity and turn the dehumidifier on and off to control the humidity level to the desired setting. The humidity setting can be adjusted from the control while the display allows easy access and monitoring of the humidity level in the space. It is recommended that the Model A76 be mounted at/near canopy height.

Press the ON button on the Model A76 to turn on the control. The UP/DOWN arrow buttons are used to set the desired humidity setting. At all other times, the Model A76 will display the measured humidity level. The Model A76 will display the diagnostic codes when a dehumidifier error occurs.

FIGURE 4 – MODEL A76 WIRING WITH DEHUMIDIFIER MODELS A200V1, A300V1 AND A300V3

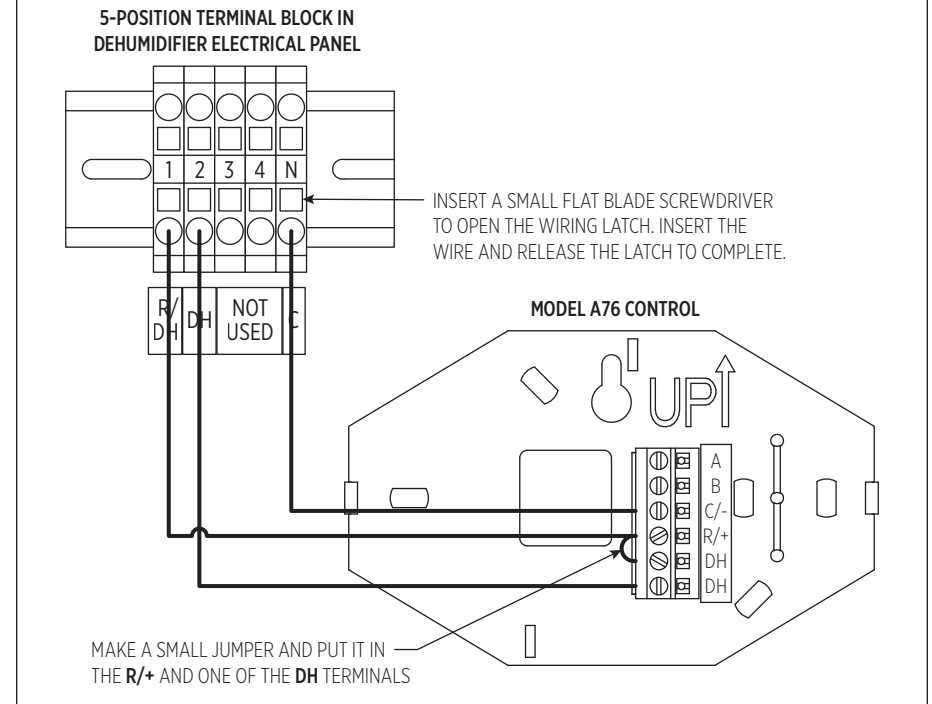

WIRING A76 WITH DEHUMIDIFIER MODELS A70, A95, A95F, A130, A130F, A210V1 AND A320V1

1. Disconnect power to the dehumidifier and HVAC system.
2. Remove the wiring access cover next to the control on the dehumidifier. See **FIGURE 5**.
3. Wire the Model A76 to the dehumidifier as shown in **FIGURE 6**.
4. Ensure the NO/NC switch on the dehumidifier control is set to NO. See **FIGURE 6**.

FIGURE 5 – WIRING ACCESS COVER LOCATION

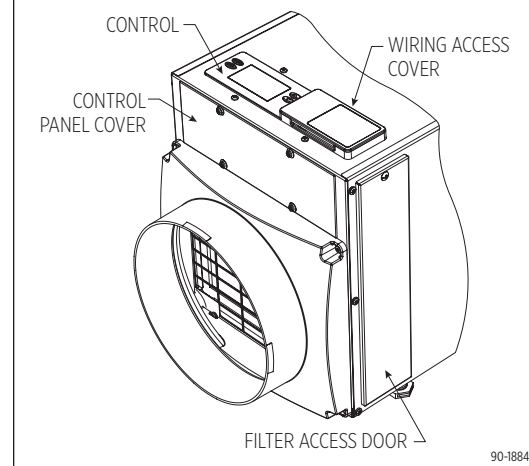
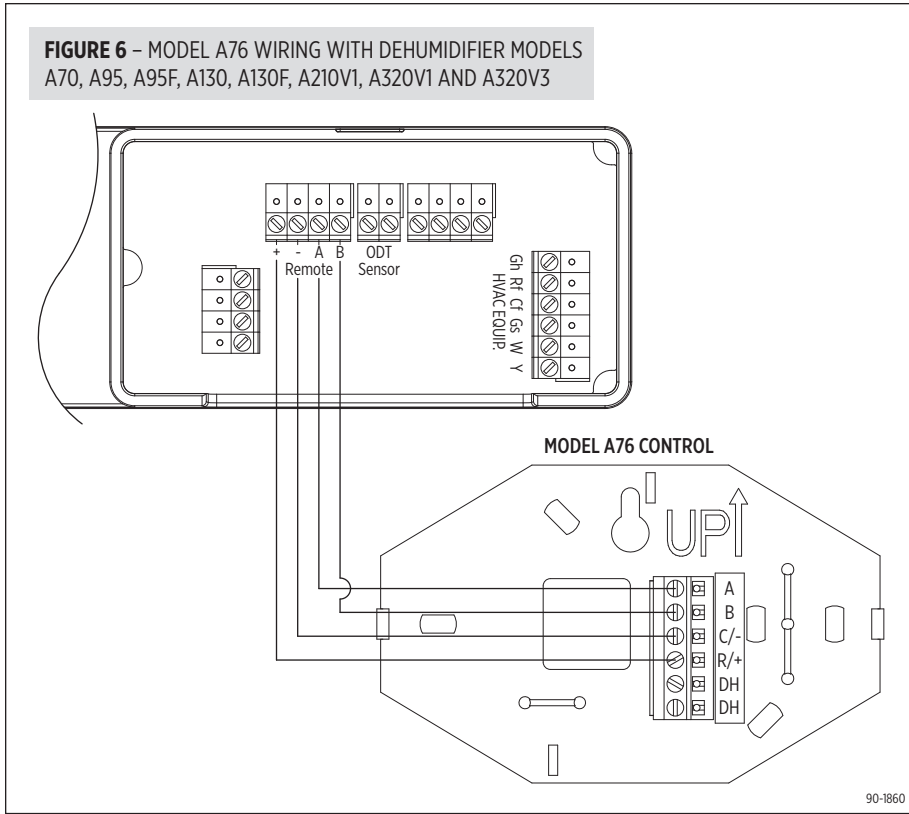
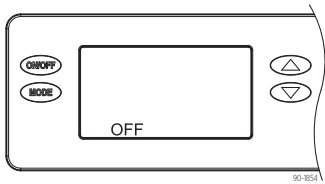

FIGURE 6 – MODEL A76 WIRING WITH DEHUMIDIFIER MODELS A70, A95, A95F, A130, A130F, A210V1, A320V1 AND A320V3



5. Snap the wiring access cover back into place, power up the dehumidifier and use the ON/OFF button to turn the unit OFF (if ON).



6. Press and hold the MODE button for 3 seconds to enter the Installer Set Up menu. "REMOTE DISABLED" will appear on the display when Installer Set Up is entered.
7. Press the UP or DOWN button to change to "REMOTE ENABLED".

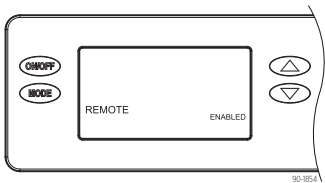

8. Repeatedly press the MODE button until "DONE" appears on the display.

SYSTEM CHECKOUT

POWER UP

1. Check all wiring.
2. Plug in dehumidifier and restore power to the HVAC system.
3. Turn on/off switch on dehumidifier ON. After a 4 second start up sequence all buttons on the Model A76 will be functional.
 - The control will be OFF.
 - The humidity setting will be 60%.
 - The control will display the measured humidity.

FIGURE 7 – EXTERNAL CONTROL

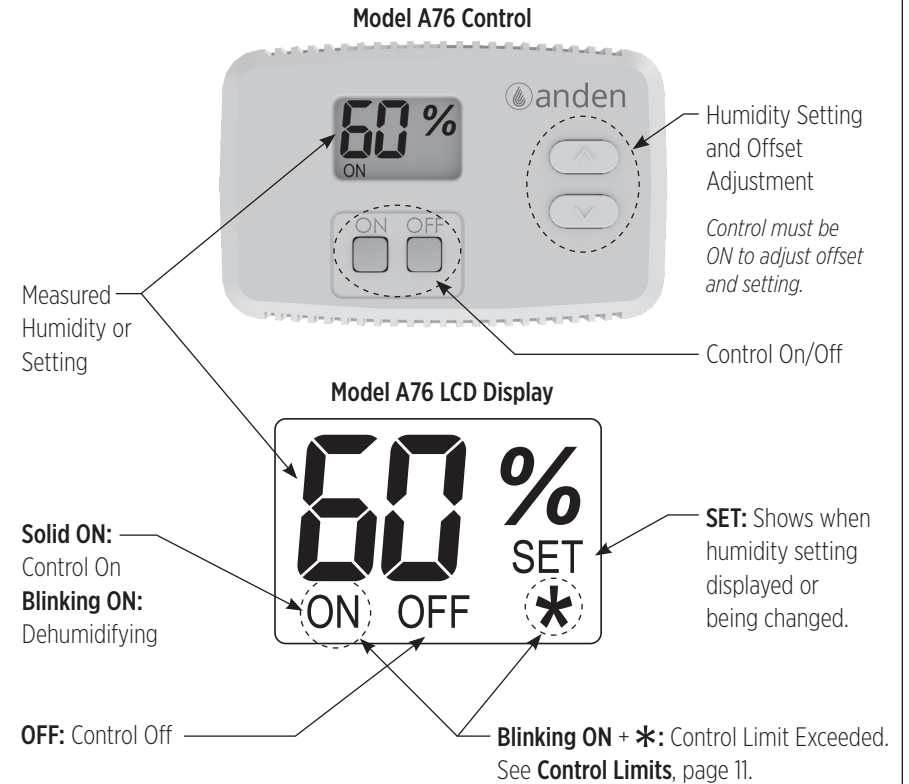

TEST MODE

1. Press and hold the ON button for 5 seconds to enter Test Mode.
 - a. Verify the measured humidity is displayed on the Model A76 screen.
 - b. Verify **ON** blinks on the Model A76 screen.
2. After 5 minutes or after pressing the OFF button, the control will enter Off mode.
 - a. Verify the dehumidifier turns off.

HUMIDITY SETTING

- The control must be ON to adjust the humidity setting.
- The **▲** (up) and **▼** (down) buttons are used to increase or decrease the setting.
- The first press of either button will display the current setting and **SET** on the LCD display.
- Each subsequent push of the up or down buttons will change the setting by 1% RH.
- If a button is held down, the setting will continually change by 1% every 1/2 second for as long as the button is pressed.
- The control will return to Normal Mode, displaying the measured humidity, 5 seconds after the last button press/release.

OFFSET

An offset can be applied to the humidity reading to avoid discrepancies with other humidity measuring devices. Allow 48 hours for the control to acclimate before applying an offset. The control must be ON to enter the Offset screen.

- Press and hold the OFF button for 5 seconds to enter the Offset screen.
- The **▲▼** buttons can be used to set an offset value between -5% RH and +5% RH.
- The control will return to Normal Mode, displaying the measured humidity, 5 seconds after the last button press/release.

FIGURE 8 – OFFSET SCREEN

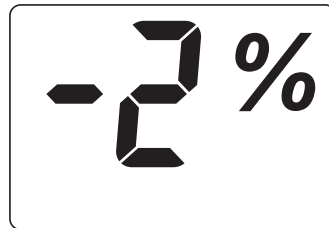

90-1636

TURNING ON AND SETTING THE CONTROL

1. Press the ON button.
2. Use the **▲▼** buttons to set the control at the desired humidity level.
 - ▲ Increasing the humidity setting will decrease dehumidifier run time, allowing for higher humidity levels.
 - ▼ Decreasing the humidity setting will increase dehumidifier run time, allowing for lower humidity levels.

SEQUENCE OF OPERATION

Normal Mode

- When the measured humidity is greater than the setting, the control will activate the dehumidifier output, the dehumidifier will begin dehumidifying and **ON** will blink on the LCD display.
- When the measured humidity falls 3% below the setting, the control will deactivate the dehumidifier output, the dehumidifier will stop dehumidifying and the LCD will display a solid **ON**.

Control Limits

- If the control measures a dew point below 40°F OR a temperature above 99°F, the control will deactivate the dehumidifier output if actively dehumidifying, the dehumidifier will stop dehumidifying, and **ON** and ***** will blink on the LCD screen.
- The control will resume normal operation when the measured dew point is greater than 45°F or the measured temperature is below 94°F, whichever control limit was exceeded.

TROUBLESHOOTING

Use the guide on the following page to help find and correct system faults. Contact Technical Support before replacing the control or for additional troubleshooting. Technical Support is available Monday through Friday, 7:00 a.m. to 5:00 p.m. CST, at (800) 972-3710.

ERROR CODES

When the control detects an internal error, it will stop controlling, deactivate the dehumidifier output, and the LCD will display the Error Code. See **FIGURE 9**. The control will attempt to recover from the error every 10 minutes. The Error Code will continue to be displayed as long as the error condition exists. Button presses are not registered when in Error Mode. Cycling power to the control will not clear the code and the control will need to be replaced.

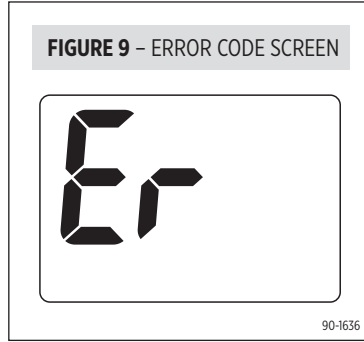

DEHUMIDIFIER DIAGNOSTIC CODES

When a dehumidifier error occurs, the diagnostic code will be displayed on the A76 screen.

TABLE 1 – TROUBLESHOOTING GUIDE

Symptom	Possible Reason	Troubleshooting Procedure
No power to the control.	Incorrect wiring.	Verify wiring connections between control, dehumidifier and HVAC system (where applicable).
	No power to dehumidifier.	<ul style="list-style-type: none"> • Verify that the dehumidifier power switch is ON. • Verify the circuit breaker has not tripped.
	No power to HVAC equipment.	<ul style="list-style-type: none"> • Verify HVAC system switch is on. • Verify the circuit breaker has not tripped.
Control does not turn on dehumidifier output.	Incorrect wiring.	Verify wiring connections between control and dehumidifier.
Blank display or missing segments during Test mode.	LCD error.	Replace control.
Display shows Er .	Control detected an internal error.	The control will need to be replaced.
Inaccurate humidity reading.	Control recently installed after being stored in an uncontrolled temperature and humidity environment.	Allow 48 hours for control to acclimate.
	Offset has been applied to the humidity reading.	Change the offset.
	Control is mounted in direct sunlight, above a heat or humidity source, or in the path of a supply register.	Relocate the control.

TABLE 2 – DEHUMIDIFIER DIAGNOSTIC CODES			
Diagnostic Code	Failure Mode	Action	Reset
E2	High Refrigeration Pressure	<ol style="list-style-type: none"> 1. Verify that the fan works, the backflow damper swings freely and there is no blocked or restricted ductwork. 2. If the fault persists, call Technical Support. 	Cycle Power
E3	Model A76 Remote Control Communication Loss	<ol style="list-style-type: none"> 1. Check connections between Model A76 and dehumidifier control board. Terminals should be fully inserted and secured in the control board and Model A76 control terminals. 2. If connections are correct and secure, turn off the dehumidifier and remove the Model A76. Use a short section of 4-wire cable to reconnect the Model A76 to the control board. Turn the dehumidifier back on and increase the dryness level setting on the Model A76. If the dehumidifier turns on, the problem is with the wiring between the dehumidifier and control. 3. If the dehumidifier does not turn on, call Technical Support. 	Self-Correcting
E4	Insufficient Capacity	<ol style="list-style-type: none"> 1. Check the frost sensor connection at the power board. Terminal should be fully seated on the power board pins. 2. Remove the side access panel and verify that the sensor is secured to the suction line. 3. If the sensor is connected and secured to the refrigeration line proceed to the next step. 4. Reset the fault by cycling power to the dehumidifier. 5. Turn the humidity setting down (below room/home humidity level) to make a dehumidification call. 6. Allow the fan and compressor to run for approximately 10-15 minutes and then enter diagnostic test mode by simultaneously pressing the UP ARROW and MODE buttons for 3 seconds. The LCD will display the temperature measured by the internal sensor while also displaying AIR SAMPLING and ON, the humidity measured by the internal sensor while also displaying %RH and ON, and the frost sensor temperature while also displaying ON. Scroll through these values and by using the UP/DOWN arrow buttons. 7. Record values and call Technical Support. 	Cycle Power

TABLE 2 – DEHUMIDIFIER DIAGNOSTIC CODES			
Diagnostic Code	Failure Mode	Action	Reset
E5	High Temperature Thermistor Failure	<ol style="list-style-type: none"> 1. Check the high temperature sensor connection at the power board. Terminal should be fully seated on the power board pins. 2. Remove the side access panel and verify the sensor is not damaged and connected to the refrigeration line coming from the compressor. 3. If the sensor is connected and secured to the refrigeration line, it may need to be replaced with Part No. 5456 – contact Technical Support to confirm. 	Cycle Power
E6	Low Temperature Thermistor Failure	<ol style="list-style-type: none"> 1. Check the low temperature sensor connection at the power board. 2. Remove the side access panel and verify the sensor is not damaged and connected to the suction line. 3. If the sensor is connected and secured to the refrigeration line, it may need to be replaced with Part No. 5455 – contact Technical Support to confirm. 	Cycle Power
E7	Float Switch Open	<ol style="list-style-type: none"> 1. Empty the condensate pan. 2. Check the float switch connection at the control board. 3. If not using a float switch, verify jumper is between float switch terminals on dehumidifier control board. 4. If the problem persists, replace the float switch. 	Self-Correcting

LIMITED WARRANTY

Your Research Products Corporation Anden™ Dehumidifier Control is expressly warranted for five (5) years from date of installation to be free from defects in materials or workmanship.

Research Products Corporation's exclusive obligation under this warranty shall be to supply, without charge, a replacement for any control which is found to be defective within such five (5) year period and which is returned not later than thirty (30) days after said five (5) year period by you to either your original supplier or to Research Products Corporation, Madison, Wisconsin 53701, together with the model number and installation date of the control.

THIS WARRANTY SHALL NOT OBLIGATE RESEARCH PRODUCTS CORPORATION FOR ANY LABOR COSTS AND SHALL NOT APPLY TO DEFECTS IN WORKMANSHIP OR MATERIALS FURNISHED BY YOUR INSTALLER AS CONTRASTED TO DEFECTS IN THE CONTROL ITSELF.

IMPLIED WARRANTIES OF MERCHANTABILITY OR FITNESS FOR A PARTICULAR PURPOSE SHALL BE LIMITED IN DURATION TO THE AFORESAID FIVE YEAR PERIOD. RESEARCH PRODUCTS CORPORATION'S LIABILITY FOR INCIDENTAL OR CONSEQUENTIAL DAMAGES, OTHER THAN DAMAGES FOR PERSONAL INJURIES, RESULTING FROM ANY BREACH OF THE AFORESAID IMPLIED WARRANTIES OR THE ABOVE LIMITED WARRANTY IS EXPRESSLY EXCLUDED. THIS LIMITED WARRANTY IS VOID IF DEFECT(S) RESULT FROM FAILURE TO HAVE THIS CONTROL INSTALLED BY A QUALIFIED HEATING AND AIR CONDITIONING CONTRACTOR. IF THE LIMITED WARRANTY IS VOID DUE TO FAILURE TO USE A QUALIFIED CONTRACTOR, ALL DISCLAIMERS OF IMPLIED WARRANTIES SHALL BE EFFECTIVE UPON INSTALLATION.

Some states do not allow limitations on how long an implied warranty lasts or the exclusion or limitation of incidental or consequential damages so the above exclusion or limitations may not apply to you.

This warranty gives you specific legal rights and you may also have other rights which vary from state to state.

WARRANTY REGISTRATION

Visit us online at anden.com to register your Anden product. If you do not have online access, please mail a postcard with your name, address, phone number, email address, product purchased, model number, date of purchase, and dealer name and address to: Research Products Corporation, P.O. Box 1467, Madison, WI 53701.

Your warranty registration information will not be sold or shared outside of this company.

anden.com

P.O. Box 1467

Madison, WI 53701-1467

800.972.3710 F: 608.257.4357

Printed in USA

©2018 Anden – A Quality brand from Research Products Corporation
10013576 B2208336A 11.18

