



pH Controller Wi-Fi User Manual



English

Contents

1.0 Introduction & Overview	3
1.1 Features.....	3
1.2 What's in the box?	3
1.3 How it works	4
1.4 Terms (Glossary).....	4
2.0 Bluelab pH Controller	7
2.1 Overview.....	7
2.2 Display	7
2.3 Connect the probes.....	8
2.4 Power up	8
2.5 Settings Menu	9
2.5.1 Set the mode	10
2.5.2 Set the required pH	10
2.5.3 Alarms (optional).....	11
2.5.4 Set the dosing direction	11
2.5.5 Dosing OnTime and OffTime	12
2.5.6 Pump Speed	12
2.5.7 Screen backlight / contrast	13
2.5.8 Number of calibration points	13
2.5.9 Display language.....	14
2.6 View current settings / status	15
2.7 Factory settings	15
3.0 Installation	16
3.1 Mounting the controller	16
3.2 Placement of the probes	17
3.3 Inlet dosing tube.....	18
3.4 Outlet dosing tube	19
3.5 Pump override (Priming)	19
4.0 Wi-Fi Connection (optional)	20
4.1 Connect for the first time.....	20
4.2 Connect to a different Wi-Fi Network	21
4.3 Enable / Disable Wi-Fi	21
5.0 pH Calibration	22
5.1 How to perform a pH calibration	22
5.2 pH calibration Tips	25
6.0 Probe Care	26
6.1 Bluelab pH Probe care.....	26
6.2 Cleaning the Bluelab pH Probe	28
6.3 Hydrating the pH probe	29
7.0 Troubleshooting & FAQ	30
7.1 Troubleshooting guide	30
7.2 Frequently asked questions.....	32
8.0 Specifications	33
8.1 Technical specifications.....	33
8.2 pH adjuster compatibility for tubing ³	34
9.0 Accessories & Warranty	35
9.1 pH Probe replacement	35
9.2 Probe Care Kits	35
9.3 Peristaltic Pump	35
9.4 Acid/Alkali Resistant Dosing Tube with Connectors.....	35
9.5 pH Probe KCl Storage Solution	35
9.6 Bluelab limited warranty.....	36
10. Get in touch	37

1.0 Introduction & Overview

1.1 Features

Built-in Wi-Fi (with option to disable)	Local and remote adjustment of control settings via Edenic by Bluelab software
Data logging capability (via Edenic by Bluelab software)	Automatic control and monitoring of system pH with reservoirs up to 2,000 US Gallons / 7,600 Litres
Flashing high and low alarms stop further dosing	Dosing lockouts to protect from over-dosing
Auto resume dosing on restart after power loss	Simple push button pH calibration with on screen instructions
Large, easy to read display	Easy to navigate menu to program and adjust settings
'Plant-safe' green back lit LCD with adjustable brightness and contrast	Water resistant, wall mount design
13 foot (4 meter) acid/alkaline resistant tubing supplied	Replaceable double junction Bluelab pH Probe
Replaceable peristaltic pump and tubing	Separate stainless steel Bluelab Temperature Probe (for pH ATC)
International power supply	

What is Plant Safe? Green lights are safe for continued growth during a plant's fruiting stage when hours of darkness are required.

What are Dosing Lockouts for? They are a built-in safety feature that stops pH dosing if an error is detected in the system (see FAQs for more detail).

1.2 What's in the box?

- 1x Bluelab pH Controller Wi-Fi
- 1x Universal Power supply 24 VDC 0.3 A output
- 1x pH Probe with 2 m (6') cable
- 1x Temperature probe with 2 m (6') cable
- 1x Acid resistant (PTFE) tubing 4 m (13')
- 2x Straight joiners (PVDF) 1/8"
- 4x Mounting screws
- 2x pH Calibration solution sachets

1.3 How it works

The Bluelab pH Controller continually monitors and controls the pH level of a solution. It utilises a separate probe for temperature and pH to accurately measure changes in your solution, and has a built-in 120ml per minute peristaltic pump.

1.4 Terms (Glossary)

Displayed pH

The current pH measured by the pH probe.

Required pH

The target pH the Bluelab pH Controller will maintain when in Control mode.

Dosing cycles

Automated control of pH is achieved by dosing. The Bluelab pH Controller does this with a dosing cycle method that consists of an OnTime and an OffTime.

OnTime

The time that the pump runs for in each dosing cycle. As a guide, three dosing cycles should change the reservoir by 0.1 pH points.

IMPORTANT

If the OnTime is too short, it is possible that the Bluelab pH Controller won't be able to dose enough to keep up with the changing pH levels, even if it doses every dosing cycle.

If the OnTime is too long, the value is likely to overshoot; i.e. a single dose changes the value so much it goes over the desired value.

OffTime

The delay time between each dose (or OnTime). This gives the system time to mix the stock solution into the reservoir thoroughly, so the Bluelab pH Controller measures the solution accurately. Start with a longer OffTime and reduce it over time.

IMPORTANT

If the OffTime is too short, the pH stock solution will not have been properly mixed in the reservoir. The Bluelab pH Controller may dose again, which can result in overshoot of the required value.

If the OffTime is too long, it is possible that the pH levels may change too much between doses.

Mixing Time

How long it takes from adding the pH solution until the pH reading becomes stable. Mixing times (and therefore the OffTime) can be reduced by installing mixing pumps, air injection or other mechanical means of mixing into the reservoir. The mixing time of the reservoir can be estimated by manually adding sufficient nutrient to significantly shift the pH value, while timing how long it takes from adding the pH solution, to when the pH reading becomes stable.

Dosing lockouts

Some conditions will cause the Bluelab pH Controller to stop controlling. These are called dosing lockouts. The three types of Dosing lockouts are Measurement range limits, Alarms, and Ineffective control lockout (each explained below).

Measurement range limits

Both of the measurement types (pH and temperature) have a measurement range within which they can measure. pH for example, can be measured between 0.0 pH and 14.0 pH; temperature between 0 °C and 50 °C.

If values outside these limits are detected, the pH Controller will indicate that it is under or over range by flashing the display and displaying “ur” or “or” in the affected measurement type. Dosing will immediately stop.

Alarms

When alarms are turned on, and the Bluelab pH Controller senses that either pH is beyond the set high or low alarm values, pH dosing will stop.

IMPORTANT

Alarms are not just warnings that values have shifted away from the required value - they stop dosing. Be careful not to set alarm values which are too close to the required values, as they may result in the Bluelab pH Controller going into alarm because of small variations in measured values.

When the values return to within the limits of the set alarms, the alarm state ceases, and after a 60 second countdown, the Bluelab pH Controller begins controlling again, dosing as required. The alarm state can also be cancelled by switching alarms off (via alarm in the menu or switching alarms off via Edenic). After a 60 second countdown the Bluelab pH Controller will begin controlling again.

Ineffective Control Lockout

The Bluelab pH Controller continually checks to ensure that dosing is having an effect. It will go into lockout if 15 dosing cycles do not move the pH value by at least 0.1 pH in the desired direction. This is called the ineffective control lockout, and is enabled by default, but can be disabled via Edenic.

The Bluelab pH Controller will indicate it is in ineffective control lockout by flashing the display and displaying 'HELP Ineffective Control'.

IMPORTANT

The ineffective control lockout is useful to stop dosing if pH solution tanks have emptied, or a hose has fallen out of a reservoir, for example.

However for a batch dosing system where fresh water is being added to the reservoir at the same time as dosing is occurring, it may be better to disable this feature.

2.0 BlueLab pH Controller

2.1 Overview

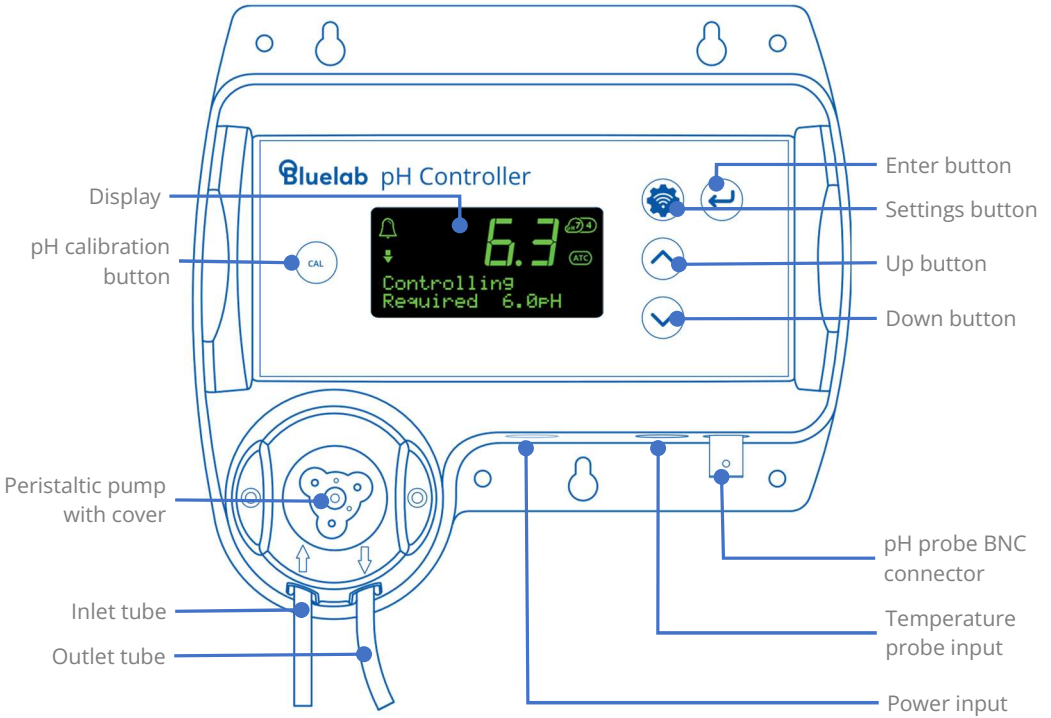

2.2 Display

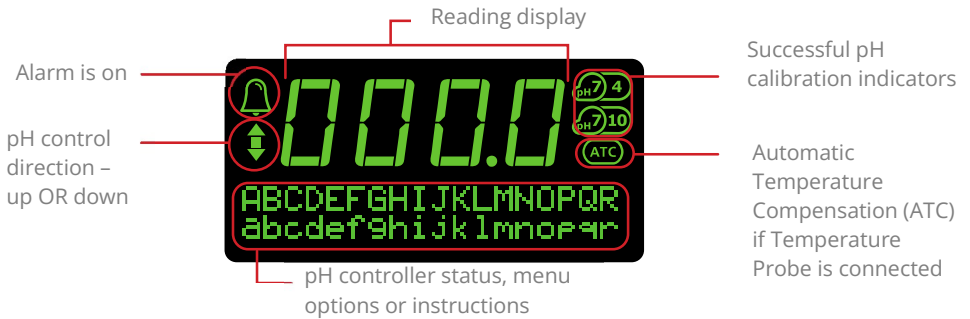



2.3 Connect the probes

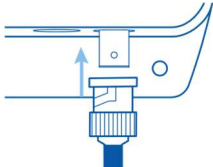
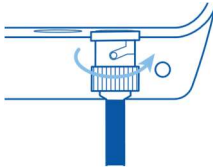
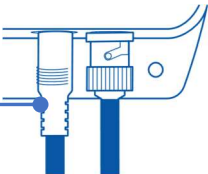

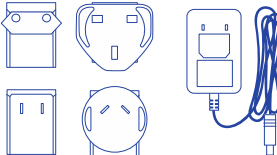
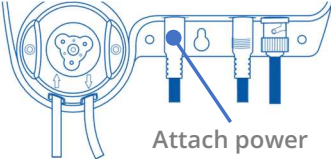

It is recommended to test the Bluelab pH Controller prior to mounting. Attach both the pH and Temperature probes to the controller, plug in the power adaptor, place probes into solution and wait a few minutes for the readings to stabilise.

<p>pH Probe</p> <p>Line up the lugs of the BNC probe connector with the receptacle on the Bluelab pH Controller labelled 'pH'.</p> <p>Fasten securely by pushing the pH probe connector on and twisting one quarter turn.</p>	 <p>Push connector</p>	 <p>Twist & attach</p>
<p>Temperature Probe</p> <p>Fully insert the temperature probe connector into the Bluelab pH Controller receptacle marked 'ATC'.</p>	 <p>Temperature probe connection</p>	

2.4 Power up

<p>Select and connect the appropriate mains plug adaptor for your region to the power supply unit.</p>	
<p>Connect the power adaptor into the Bluelab pH Controller receptacle marked 'PWR'.</p>	 <p>Attach power adaptor</p>
<p>Plug the power adaptor into a mains outlet and switch it on. The Bluelab pH Controller will complete a display test sequence.</p>	
<p>The default setting, is 'monitoring' mode.</p> <p>Note: pH calibration must be completed before the first use, see section 5.0 to ensure pH readings are accurate.</p>	

2.5 Settings Menu

<p>The 'Settings' button will take you into the menu. To exit the menu, press 'Settings' again. Changes will not be saved.</p>	
<p>The '∧' (up arrow) button allows you to move up the menu items or increase a value shown. The '∨' (down arrow) button allows you to move down the menu items or decrease a value shown. To use the 'Auto-repeat' feature: Press and hold the '∧' (up arrow) or '∨' (down arrow) button to scroll through options. Release when you see the desired option or value on the screen.</p>	 
<p>The '↵' button allows you to select the desired option shown on the display or save a chosen value.</p>	
<p>The 'CAL' button is used to calibrate your pH probe. A long press enters the calibration sequence.</p>	

Adjusting Settings

To adjust any of the settings, modes or alarms

1. Press the 'settings' button.
2. '∨' or '∧' to find the menu option required.
3. '↵' to enter that menu item.
4. '∨' or '∧' to adjust the parameter.
5. '↵' to save the change.
6. 'Settings' button to exit.

If you have adjusted a parameter and don't want to save, you can let the menu timeout or press the 'settings' button which will exit without saving.

2.5.1 Set the mode

The Bluelab pH Controller has two modes of operation (monitor and control).

Monitor mode displays the current solution pH reading.

Control mode allows the pH controller to dose pH solution to the set values.

Dosing will NOT occur when:

- The pH controller is in **'monitor'** mode
- The pH controller is in an **alarm** state
- The pH controller is in **ineffective lockout** state.
- The solution temperature is above 50 °C / 122 °F, or below 0 °C / 32 °F

To set 'monitor' mode (set by default):

1. In the menu select 'Mode', press '↓' to enter.
2. Press 'v' or '^' to select 'monitor'
3. Press '↓' to save the mode.



To set 'control' mode:

1. In the menu select 'Mode' and press '↓' to enter.
2. Press 'v' or '^' to select 'control'
3. Press '↓' to save the mode.

The display will show a countdown before the pump can start. This is: 15 sec when exiting the menu with control mode enabled; 60 sec if power off/on occurs.



2.5.2 Set the required pH

1. Select 'Set pH' and press '↓' to enter.
2. Press 'v' or '^' until the required pH is shown in the main display.
3. Press '↓' to save the value.

Note: If you have already set high and low alarm values, you may see the values change depending on the pH value being set



2.5.3 Alarms (optional)

- The alarm function alerts you when the solution deviates too far from the desired pH. When an alarm condition is present, the pH value and the alarm symbol will flash on the screen. This is an 'alarm lockout' state. All dosing will stop.
- If the measurement changes back to within the limits you have chosen, the flashing will stop and dosing will start.

To set the 'High Alarm' value:

Use the menu item 'Alarm High'



To set the 'Low Alarm' value:

Use the menu item 'Alarm Low'



To turn the alarm on or off:

Use the menu item 'Alarm'



2.5.4 Set the dosing direction

Use the menu item 'Dose'

Select 'Down/Acid' for dosing acid (pH down solution).

Select 'Up/Alkali' for dosing alkali (pH up solution)



2.5.5 Dosing OnTime and OffTime

- A dosing cycle includes the OnTime and the OffTime that the peristaltic pump doses for. The arrow symbol on the display will flash during the dose cycle.
- Adjustments for OnTime and OffTime will be required so that **three** dosing cycles only change the pH value by 0.1 pH.
- Start with a long 'OffTime' and adjust back as you go. The more thorough the mixing in the tank, the shorter the 'OffTime' can be.

To set the OnTime value:

Use the menu item 'OnTime'

'OnTime' the length of time pump will dose for. From 1 to 60 seconds.



To set the OffTime value:

Use the menu item 'Off Time'.

'OffTime' the delay time between each dose. This gives the system time to mix the stock solution into the reservoir thoroughly, so the BlueLab pH Controller measures the solution accurately. From 1 to 60 minutes.



2.5.6 Pump Speed

To change the pump speed:



Use the menu item 'Pump Speed'

Can be set at 20%, 40%, 60%, 80% or 100%. The default is 100%.

Note, the actual flow rate will not change linear due to tubing size and viscosity of liquid. Always test the flow rate to ensure it takes at least three dosing cycles to change your reservoir pH by 0.1.



2.5.7 Screen backlight / contrast

<p>To change the screen backlight:</p> <p>Use the menu item 'Backlight'</p> <p>Can be set at 0%, 25%, 50%, 75% or 100%.</p>	
<p>To change the screen contrast:</p> <p>Use the menu item 'Contrast'</p> <p>Can be set between 0 and 30.</p>	

2.5.8 Number of calibration points

<p>If you are calibrating to TWO solutions, remember:</p> <p>If a reading below pH 7.0 is expected, use pH 7.0 and pH 4.0 calibration solutions. If a reading above pH 7.0 is expected, use pH 7.0 and pH 10.0 calibration solutions.</p> <p>You would require calibration in THREE solutions if:</p> <p>Readings above and below pH 7.0 are expected, use pH 7.0, pH 4.0 then pH 10.0 calibration solutions. You will need to enable 3-point calibration in the settings menu.</p>

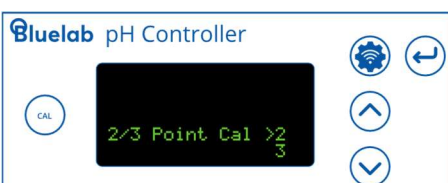
<p>To change the calibration point:</p> <p>Use the menu item '2/3 point Cal'</p>	
---	--

2.5.9 Display language

Use the menu item 'Language'



2.6 View current settings / status

Use this option to view your programmed settings at any time.

Press 'v' or '^' while in 'monitor' or 'control' mode. The setting for each value is displayed at the bottom of the screen.

The display will revert to displaying 'Required pH' if no button is pressed after 1 minute.



2.7 Factory settings

The pH controller is set to the following values by default:

- | | | | |
|--------------|-----------|------------------|---------|
| • Mode | Monitor | • Backlight | 100% On |
| • Set pH | 5.8 | • Pump Speed | 100 |
| • Alarm | On | • Contrast | 6 |
| • HighAlarm | 6.5 | • 2/3 point Cal | 2 |
| • LowAlarm | 5.6 | • EarthLink | Off |
| • Dose Up/Dn | Down/Acid | • Wi-Fi | On |
| • OnTime | 1 Sec | • Language | eng |
| • OffTime | 10 Min | • pH Calibration | none |

Note: 'Pump' runtime [HH:MM:SS] is the time the pump has dosed for. Product 'RunTime' [Hrs] is the duration of time the pH controller has been in use for. Pump runtime and product runtime are never reset, even after pump replacement.

To restore the pH controller to the above factory settings at any stage:

- Disconnect the power
- Press and hold the 'CAL' button then reconnect the power.
- When 'Restored Factory Defaults' is displayed on the screen, release the 'cal button'.

3.0 Installation

3.1 Mounting the controller

Select a suitable location that is:

- Less than 5.65 feet / 2 meters from your reservoir. The probes must be immersed in solution at all times. Less than 4.9 feet / 1.5 meters from an electrical mains outlet.
- Less than 5.56 feet / 2 meters from pH Up or Down solution. The inlet tube must reach the bottom of the container.
- At a suitable height to see the display and for easy operation (recommend slightly below eye level when standing).

NOTE: Avoid placing the pH controller where it can be damaged by direct sunlight, water, nutrient salts or pH adjuster.

Fix the fasteners through the desired mounting holes in the top and bottom of the case.

Mounting holes at top

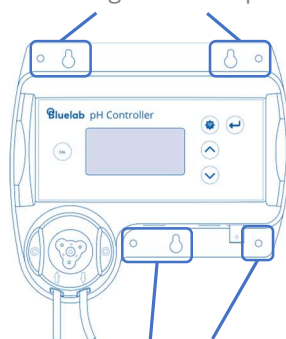

Mounting holes at bottom

3.2 Placement of the probes

- The tip of the BlueLab pH Probe must be submerged in the liquid for a measurement to occur. It is optional to use the BlueLab Temperature Probe, but it is required for automatic temperature compensation (ATC) to occur, or to enable 'Earthlink'.
- *Do not pour concentrated nutrient solution or pH adjuster directly onto probes when in the reservoir. Strong acids, alkali and nutrients damage the probes, trigger the alarms (if on), cause the pump to accidentally dose or stop dosing, or interfere with the control program.*
- *For accuracy, ensure the probes are in an area where the reservoir/tank solution is well mixed.*
- *pH and temperature probes can be fully submerged in the solution.*

1. Remove the storage cap from the pH probe by gripping the top of the cap and gently twisting the base one rotation to loosen. Slide the storage cap off the pH probe.



2. Fit the (optional) pH probe holder to the stem of the pH probe using a gentle twisting motion.
3. Place the pH probe into the reservoir/tank and push the suction cup onto the side of the probe tip in the reservoir but far enough down so the pH probe tip is always in the solution. This prevents damage to the probe from any movement in the reservoir/tank.
4. Place the temperature probe alongside the pH probe.

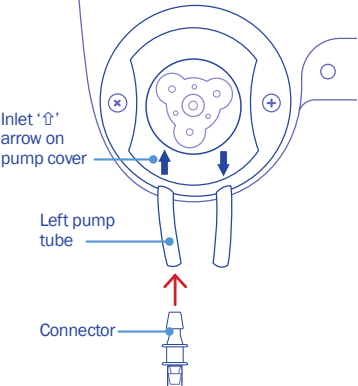
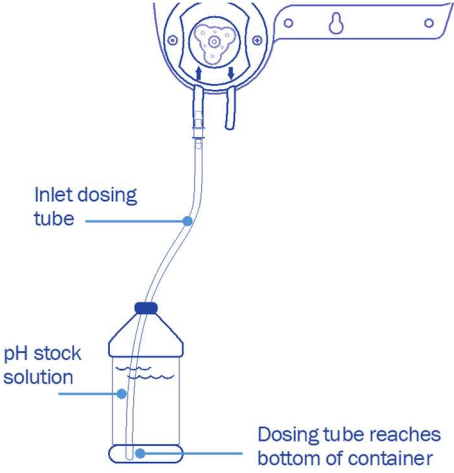
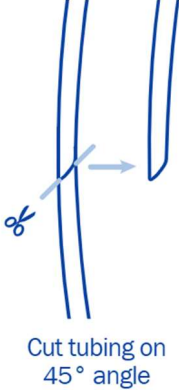

3.3 Inlet dosing tube

<p>To straighten tube: Bend tube in the opposite direction and straighten by running through closed fingers.</p>	 <p>Inlet '\u2191' arrow on pump cover</p> <p>Left pump tube</p> <p>Connector</p>
<p>Insert one end of the dosing tube with connector into the LEFT peristaltic pump tube. This is the 'inlet dosing tube'.</p>	
<p>Ensure the inlet dosing tube will reach the bottom of the pH stock solution container.</p>	 <p>Inlet dosing tube</p> <p>pH stock solution</p> <p>Dosing tube reaches bottom of container</p>
<p>Cut the bottom end of the tube on a 45° angle to avoid the tube becoming stuck to the bottom and blocked.</p>	 <p>Cut tubing on 45° angle</p>

3.4 Outlet dosing tube

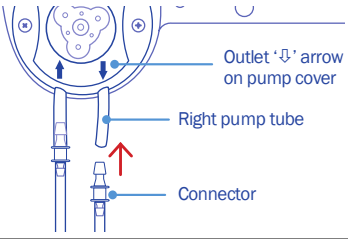
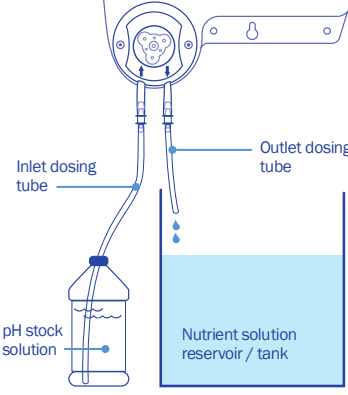
<p>Insert the remaining dosing tube with connector into the RIGHT peristaltic pump tube. This is the 'outlet dosing tube'.</p>	
<p>Cut the outlet dosing tube so that the tube sits above the maximum solution level of the reservoir/tank. The pH stock solution must drip into the nutrient reservoir/tank.</p> <p>Note: If the outlet dosing tube is immersed in reservoir/tank solution, it could create a syphon. This would cause the pH stock solution to overflow.</p>	

3.5 Pump override (Priming)

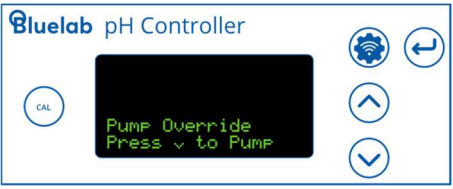
<p>'Pump Ovrde' allows you to fill the inlet and outlet tubes with dosing solution before first use (removing any air in the tubes), and to manually dose the tank if required.</p> <p>NOTE: If priming the pump, temporarily move the outlet dosing tube so it runs into the pH stock solution container (if not already fixed in place). This will avoid adding pH stock solution to your tank/reservoir unintentionally.</p>	
<p>Use the menu item 'Pump Ovrde'</p> <ol style="list-style-type: none">1. Press 'v' to manually operate the pump.2. Release the button to stop the pump when you see the stock solution begins to drip from the outlet dosing tube.	
<p>CHANGING STOCK SOLUTION: If you are changing from pH Up to pH Down, or vice versa, you MUST flush the dosing tube with water FIRST to avoid a chemical reaction in the tube.</p>	

4.0 Wi-Fi Connection (optional)

4.1 Connect for the first time

To connect the device to Wi-Fi, it is helpful to have the onboarding QR code available for scanning. This can be found on the back of the device or on the packaging.

Have the security code QR image handy.

Example:



Name :

BlueLab-2c3e

Security code:

1a2b

When first powered on, the pH Controller Wi-Fi automatically starts in Provisioning mode. This allows Wi-Fi settings to be configured from a mobile device. Once the pH controller has been connected to a Wi-Fi network it will no longer start in Provisioning mode. If you need to connect to a new network, see section 4.2.

1. Ensure Bluetooth is enabled on your mobile device and the Edenic app is installed.
2. Open the Edenic app on your mobile device and log in.
3. Remove the pH Controller power cable for a few seconds then reconnect.
4. In the Edenic app, click the add device button in the bottom right.
5. Select scan a QR code.
6. Scan the QR code provided on the back of your pH Controller / packaging.
7. Enter a device name to help you recognise this pH controller Monitor.
8. Wi-Fi details – Click the view Wi-Fi networks to see available networks.
9. Select the Wi-Fi network you want to connect to.
10. Enter the Wi-Fi network password.
11. Select continue, your device will now be ready and connected.

4.2 Connect to a different Wi-Fi Network

To reprovision:

1. Use the menu item 'Wi-Fi'.
2. Press '↵' to select 'Provisioning'.
3. The security code is displayed indicating that the device is ready to accept new Wi-Fi settings.
4. Use the Edenic App on your mobile to complete the setup for a new network.



4.3 Enable / Disable Wi-Fi

By default, Wi-Fi is enabled. If you want to disable Wi-Fi follow these instructions:

1. Use the menu item 'Wi-Fi'.
2. If turned on, the status is shown above the menu.
 - a. Conn – Wi-Fi is connected
 - b. Err1 – Wi-Fi not connected
 - c. Err2 – No internet available
 - d. Err3 – Edenic service not reachable
 - e. Err4 – Time sync, please wait.
3. Select 'Data' and '↵' to enter Data menu.
4. Select Off to disable Wi-Fi.
On to enable.



5.0 pH Calibration

pH calibration is important before first use. It ensures pH measurements and/or pH stock solution dosing is accurate.

The BlueLab Temperature Probe DOES NOT require calibration but is used for ATC.

The pH calibration involves cleaning **the pH probe tip and then calibrating in TWO or THREE SOLUTIONS.**

For accurate pH readings the pH probe should be cleaned, and calibration carried out when:

- The device is using factory defaults (the calibration indicators are not lit).
- 30 days since the last pH calibration (calibration indicators are flashing).
- the reading is different to what you were expecting.
- the pH probe is replaced with a new one.

If the pH probe has been in use, it should be cleaned before pH calibration. See section 6.2 for pH probe cleaning. New pH probes do not need to be cleaned.



If you are calibrating to TWO points, remember:

If a reading below pH 7.0 is expected, use pH 7.0 and pH 4.0 calibration solutions. If a reading above pH 7.0 is expected, use pH 7.0 and pH 10.0 calibration solutions.

You would require calibration in THREE solutions if:

Readings above and below pH 7.0 are expected, use pH 7.0, pH 4.0 then pH 10.0 calibration solutions. You will need to enable 3-point calibration in the settings menu.

5.1 How to perform a pH calibration

To calibrate the pH	
Clean pH & Temperature probe tips. See section 6.2 on how to clean the pH probe (the pH & Temperature probes does not require cleaning before the first use).	 
The calibration default is set at two-point calibration. If a three-point calibration is required view section 2.5.7.	

In several separate plastic containers, prepare a small amount of:

- fresh tap water
- pH 7.0
- pH 4.0 and/or pH 10.0 calibration solutions.

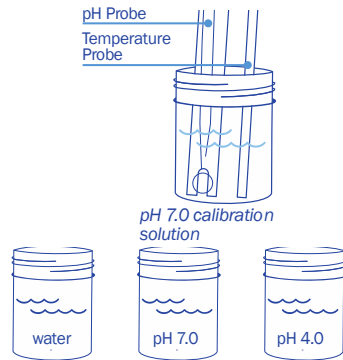

pH 7.0 calibration

1. Rinse and place both clean pH and Temperature probe tips in the pH 7.0 calibration solution.
2. Wait a few minutes for the probes to come to the same temperature as the solution.
3. Press and hold 'CAL' for three seconds. 'pH 7 Calibrate' will be displayed.
4. Press 'CAL' to initiate calibration.
5. Calibration is complete when all the ' 's on the screen become solid. The screen will display 'OK' and the 'pH 7' indicator will appear to indicate successful pH 7.0 calibration.
6. Now you can calibrate to pH 4.0 and/or pH 10.0

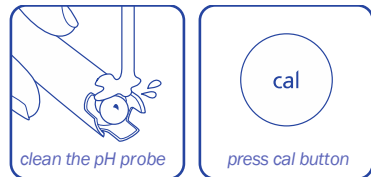

successful pH7 calibration



ready for pH 4 or pH 10 calibration

pH 4.0 and/or pH 10.0 calibration

1. Rinse both probe tips in fresh tap water, shake off excess water. Place the clean pH probe tip in either pH 4.0 or pH 10.0 calibration solution. Press 'CAL'.
2. Calibration is complete when all the ' 's on the screen become solid. The screen will display 'OK' and the 'pH 4' or 'pH 10' indicator will appear to indicate successful pH calibration.
3. If you require three-point calibration, repeat '1' and '2' using the pH 4.0 or pH 10.0, whichever solution was not used.
4. The pH controller is now calibrated, and ready for use.

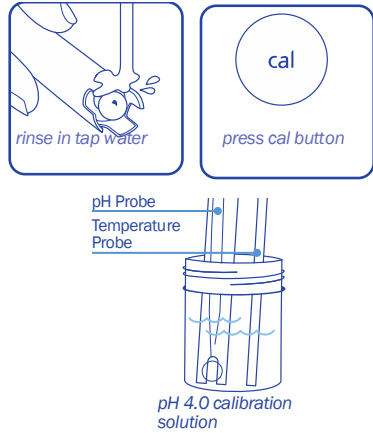

After pH calibration, the pH controller reverts to 'Monitor' mode.

Change to 'Control' mode if required.

NOTE: If 'Failed ζ' is displayed on the screen during calibration, see section 7.1 Troubleshooting.

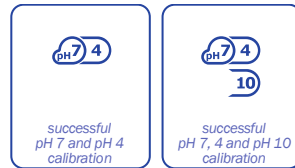

5.2 pH calibration Tips

For best pH calibration

pH reading accuracy is dependent on the accuracy and age of the calibration solutions used and the use and cleanliness of the pH probe tip.

- Ensure the pH probe has been cleaned and rinse with clean water between calibration solutions to reduce contamination of the pH solutions.
- Only fresh uncontaminated solutions should be used.
- Calibrate the pH at the same temperature as the solution to be measured.
- ALWAYS calibrate the pH probe with pH 7.0 then to pH 4.0 and/or pH 10.0.
- Place the temperature probe into the calibration solution with the pH probe during calibration.
- Allow for the pH probe to reach the same temperature as the solution.

Storage and use of calibration solutions

- Always place the lid back onto the bottle after use or evaporation will occur rendering the solutions useless.
- DO NOT measure directly into the bottle. Tip a small amount into a clean container and discard after use.
- Never add water to solutions.
- Store in a cool place.



6.0 Probe Care

6.1 Bluelab pH Probe care

pH probes DO NOT last forever. They age through normal use and will eventually fail. The lifetime of a pH probe depends on the environment it is used in and the way that it is treated. To receive a long life from your Bluelab pH Probe, please ensure you follow the guide below.

pH probes contain glass and are therefore FRAGILE. With good care, they will give a long service life.

Bluelab pH probe



DO NOT let the pH probe tip dry. **IF IT DRIES IT DIES!**

DO NOT bend the probe; this will break its internal glass tube.

DO NOT knock the probe; this will break its internal glass tube or external glass bulb.

DO NOT plunge a cold pH probe into a hot liquid, or a hot probe into cold liquid.

Sudden temperature changes can crack the glass and permanently damage the probe.

DO NOT immerse in oils, proteins or suspended solids that will leave a coating on the glass bulb.

DO NOT 'kink' or bend the lead sharply.

DO NOT attempt to lengthen the lead on the pH probe.

DO NOT wet the BNC connector at the end of the lead.

Always remove pH probe storage cap before use

- Grip the top of the cap and gently twist the base one rotation clockwise to loosen slightly.
- Next slowly slide the cap off the pH probe. **DO NOT** completely remove the base of the cap from the top of the cap.
- Store the storage cap in a safe place.

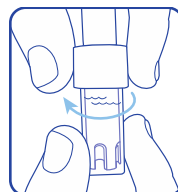

Removing pH probe storage cap

Storing the pH probe

When storing the pH probe, the pH probe tip must be kept moist.

To prepare the pH probe for storage, add enough BlueLab pH Probe KCl Storage Solution to the storage cap so the probe tip is covered. Then replace the cap and store in a secure place. DO NOT use RO (Reverse Osmosis), Distilled or

De-ionized water. Pure water changes the chemistry in the reference, causing the probe to die.

If the pH probe has been accidentally allowed to dry out;

The pH probe must be 'hydrated' for 24 hours in KCl storage solution (never use RO, Distilled or De-ionized water). Following this; carry out a calibration to check if the probe has already suffered permanent damage.

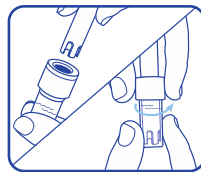

Ensure probe tip is covered by the KCl storage solution in cap

6.2 Cleaning the Bluelab pH Probe

To ensure accurate readings the pH probe tip needs to be rinsed in water and cleaned prior to calibration using the following instructions. After cleaning, use the probe straight away, or place the storage cap on the probe tip. Always ensure the cap contains enough Bluelab pH Probe KCl Storage Solution to cover the probe tip.

Remove storage cap from pH probe.
Hold the top of the storage cap, twist the cap to loosen then remove.

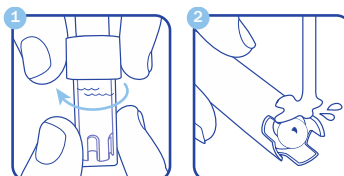

Rinse pH probe tip under fresh tap water.

Fill a small plastic container with clean tap water. Add a small amount of Bluelab pH Probe Cleaner or mild detergent (dishwashing liquid).

Gently stir the probe tip in the mixture. Ensure that you do not 'knock' the pH probe on the side of the container as this may cause damage to the probe.

Rinse well under fresh running water to remove all traces of the detergent mixture.

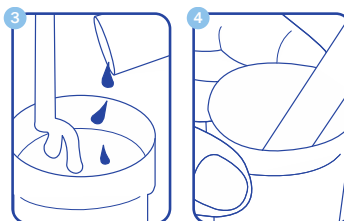

If the probe tip requires removal of heavy contamination:

Gently brush around the glassware with a few drops of Bluelab pH Probe Cleaner or mild detergent (dishwashing liquid) and a soft toothbrush.

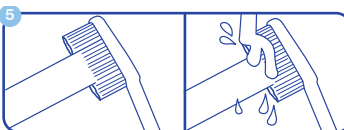

Rinse well under fresh running tap water to remove all traces of the detergent mixture.

Calibrate pH probe after cleaning, see section 5.1. After calibration use straight away or store pH probe in the storage cap, ensuring there is enough KCl Storage Solution to cover the probe tip.

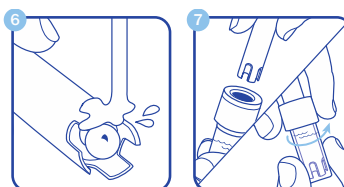

6.3 Hydrating the pH probe

Hydrate the pH probe in Bluelab pH Probe KCl Storage Solution when:
the probe tip has not always been stored in KCl storage solution, to improve the reading response speed.
the probe tip has been accidentally allowed to dry out.
Never store the pH probe in RO (Reverse Osmosis), De-ionized or Distilled water. Pure water changes the chemistry in the reference, causing the probe to die.

Clean the pH probe tip. Ensure the probe tip is cleaned before hydrating. See section 6.2 for instructions.

Add enough Bluelab pH Probe KCl Storage Solution to a plastic container to submerge the pH probe tip.

Loosen, then remove the storage cap (if required). Place the pH probe upright in a the KCl solution.

Leave to soak for up to 24 hours. After hydration, always calibrate the pH probe to ensure accuracy, see section 5.1.

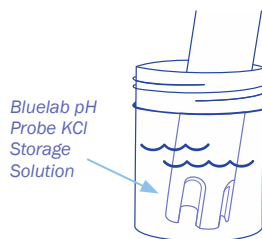

7.0 Troubleshooting & FAQ

7.1 Troubleshooting guide

Trouble	Reason	Correction
pH reading inaccurate	pH probe not plugged in.	Connect pH probe. Check pH probe connection.
	Using factory default calibration.	Calibrate pH probe.
	Contaminated pH probe / glassware not clean.	Clean pH probe, then calibrate.
	Broken glass bulb, tube or connector.	Replace pH probe.
	pH probe damaged or old.	Replace pH probe.
	Bad grounding (noisy/jumpy pH readings).	Earthlink required. Attach temperature probe. Go to Menu, turn Earthlink on.
Display shows 'Failed <e>' during calibration	Old or contaminated solutions used to calibrate.	Use fresh calibration solutions.
	Dirty or contaminated pH probe.	Clean pH probe.
	pH probe tip been allowed to dry.	Hydrate pH probe.
	pH probe damaged or old.	Replace pH probe.
No display	Mains not switched on.	Switch mains power on.
	Power adaptor not plugged in.	Plug power adaptor into the power socket marked 'PWR'.
	Mains on, power adaptor plugged in.	Replace power adaptor.
No display after initial LCD test	Backlight set to minimum.	Increase Backlight setting in MENU, or hold <cal> button down while applying power, to restore Factory Defaults.
pH displays 'or', 'ur', '-.-'	'or' Over range pH. 'ur' Under range pH.	Check pH probe connection. pH probe could be faulty. Clean pH probe, then calibrate.
	'-.-' Temperature over/under range.	Solution <0°C / 32°F or >51°C / 122°F. Check solution temperature. Ensure temperature probe plug is fully inserted.
Temperature displays 'or', 'ur', '-.-'	'or' Over range temperature. 'ur' Under range temperature.	Solution >51 °C / 122 °F. Solution <0 °C / 32 °F.
	'-.-' Temperature probe not connected.	Ensure temperature probe plug is fully inserted. Temperature probe is faulty, replace.
pH symbols flashing	It has been more than a month since last calibration.	Clean pH probe, then calibrate.
'HELP' flashing [Ineffective control detected]	Dosing solution container empty.	Refill dosing solution container.
	Dose direction setting incorrect for your system.	Ensure setting reflects dosing solution in use. i.e. For Acid select Down.
	Dose on/off times incorrect.	See section 2.5.5 for setting Dose On/Off times.
	Output from tube not dripping into solution.	Ensure tube output drips into tank.
	Solution is not mixing.	Ensure pH correction solution is mixed in tank.
	pH probe not seeing pH changes, after dosing	Ensure pH probe is in solution with adequate mixing.

**Wi-Fi
Connection
to Edenic
isn't working**

Wi-Fi is disabled on the pH Controller	<ol style="list-style-type: none">1. Select 'Wi-Fi' in the menu.2. Select On to enable Wi-Fi.
The Wi-Fi menu displays; Err1 – Wi-Fi not connected	Wi-Fi network is not provisioned correctly, reprovision your pH controller to the local Wi-Fi network. Device is outside Wi-Fi range of your router Move the pH Controller to be close (< 5 meters) to Your wi-fi router. If that fixes the issue you will need a Wi-Fi repeater or a more powerful router.
The Wi-Fi menu displays; Err2 – No internet available	
The Wi-Fi menu displays; Err3 – Edenic service not reachable	Issue with the BlueLab server, if the problem persists for more than 2 hours please contact BlueLab support.
The Wi-Fi menu displays; Err4 – Time sync, please wait.	Issue with the BlueLab server, if the problem persists for more than 2 hours please contact BlueLab support.

7.2 Frequently asked questions

Question	Answer
Why is the '↑' or '↓' flashing but the pump is not turning?	The '↑' or '↓' will flash whenever the pH controller is in a dose cycle. This includes the 'OnTime' and 'OffTime'. The pump does not turn during the 'OffTime'.
What are dosing lockouts?	A feature that stops the pH controller from dosing if: <ul style="list-style-type: none"> The temperature probe measures a solution temperature of less than 0 °C / 32 °F or more than 50 °C / 122 °F. The pH reading does not change after 15 dose cycles.
Can Ineffective lockout be disabled?	Ineffective Lockout can only be disabled via the Edenic by BlueLab software.
Do I need to use the temperature probe with ATC for pH?	You can omit use of the ATC probe if: <ol style="list-style-type: none"> You do not use EarthLink On setting to stabilise the pH value Your solution temperature is stable, and you calibrate the pH probe in calibration solutions at the same temperature as the reservoir / tank solution. Your pH is close to 7.0 pH
Why should I use Earthlink?	To remove/reduce any "mains earthloop" issues affecting the pH value's stability.
How do I use Earthlink?	Ensure the ATC probe is installed and in the same solution as the pH probe. Press 'V' to view status of pH mV value behaviour. Change the Earthlink setting in MENU and watch the pH mV value again. Select the Earthlink option that gives the least pH mV noise/variation. If neither option improves pH stability: <ol style="list-style-type: none"> Calibrate pH probe, see section 5.1. Suspect Mains electrical problems. Obtain Electrician assistance.
How do I determine the best Dose OnTime/ OffTime values?	Adjust OnTime such that 3 to 5 doses shifts the pH by only 0.1pH. If <= 2 doses moves pH more than 0.1pH, you risk overdosing. (pH changes past Required Value). If it takes >=5 doses you will have a slow response to any changes. You may also get "HELP" displayed if pH hasn't moved enough if 15 dose cycles. If < 3 doses at 1 sec OnTime shifts the pH more than 0.1pH, you will need to dilute the dosing solution to a lower concentration. <p>Adjust OffTime such that the last dose is fully mixed before the next dose cycle starts. If OffTime is too short, you risk overdosing (pH changes past Required Value). If OffTime is too long, correction to pH changes will take longer than necessary.</p>
How do I reset the pH controller to "as Shipped Defaults"?	Hold <CAL> button down and apply power. Release button when "Restored Factory Defaults" appears on screen.
How do I reset pH calibration to "Defaults"?	The pH probe can be calibrated anytime to the pH controller. Follow the calibration steps in section 5.1. Hold <CAL> button down till "pH Calibration Reset to Default" is displayed then press 'J' to reset.

8.0 Specifications

8.1 Technical specifications

pH	
Control parameter	pH - user selectable single direction (up or down)
Control range	0.1 – 13.9 pH
Dose rate	120 ml per minute
Resolution	0.1 pH
Accuracy at 25°C/77°F	±0.1 pH
Calibration	Two or three point (pH 7.0 and pH 4.0, and/or pH 10.0)
Temperature compensation	Yes (if temperature probe is in the same solution as pH probe)
Operating environment	0 - 50°C / 32 - 122°F
Power source	Input: 100-240 Vac, 50-60 Hz, 4 interchangeable plug types (USA, Euro, UK, NZ/AUS) Output: 24 VDC 0.3 A
Input Power	24VDC, 0.3 A (Must use power supply provided)
Screen display languages	English, Nederlands, Deutsch, Français, Español
User Manual languages	English
Certifications	CE, FCC, IC. Contains Wi-Fi/Bluetooth Module IC: 21098-ESPS3WROOM1, FCC ID: 2ACZ7-ESPS3WROOM1
Signal Range	Indoor / Urban: 66 feet / 20 meters Outdoor : 164 feet / 50 meters
Radio Signals	Wi-Fi: 2.4 GHz (802.11 b/g/n) Bluetooth: 5 (Low Energy)
System Requirements	Android (8.0 or later) or iOS (12 or later) Mobile phone for Edenic Software. Internet connection for remote access & data-logging.
Tubing	Within the Peristaltic Pump – PharMed BPT Supplied as additional - PTFE

Typical Installation Environment

Moisture exposure	Not IP rated. Indoor installation recommended, outdoor installation should provide protection from moisture ingress via separate enclosure or rain cover.
Altitude	Less than 2000m
Humidity	5-95% relative humidity
Pollution degree of the intended environment	Pollution degree 2

8.2 pH adjuster compatibility for tubing³

Bluelab does not recommend the use of highly concentrated acid or alkaline with this product as it is likely to cause damage to the pump tubing. Many leading brands of pH Up and pH Down are appropriate for use without dilution. As a guide Bluelab recommends the following maximum concentration for commonly used acids and alkalines;

pH Controller tubing

PharMed BPT & PTFE

Nitric Acid	<35%
Phosphoric Acid	<85%
Sulfuric Acid	<30%
Citric Acid	<60%
Potassium Hydroxide	<60%
Potassium Carbonate	Concentrated
Potassium Silicate	<60%

³ The chemical concentrations stated in the above table are a guide. Variations in temperature, pressure, or UV exposure may cause tubing failure which could lead to serious injury if proper safety precautions are not followed. For this reason, it is recommended that the tubing be tested with the desired chemical in the specific application to determine suitability. No warranty (neither express or implied) is given that the information in these tables is accurate or complete or that any material is suitable for any purpose.

9.0 Accessories & Warranty

9.1 pH Probe replacement

pH probes do not last forever.

They age through normal use and will eventually fail to calibrate.

To get the most life out of your pH probe, please read the instructions provided with it.

9.2 Probe Care Kits

The instrument is only as accurate as the probe is clean!

Probe cleaning is one of the most important parts of owning and operating any Bluelab meter, monitor or controller.

If the probe is contaminated (dirty) it affects the accuracy of the reading displayed.

Bluelab Probe Care Kit – pH contains:	
› Probe care instructions	› Bluelab pH Probe Cleaner
› 3 x plastic cups	› Toothbrush (pH probe cleaning instrument)
› 20ml single-use Bluelab Solution Sachets, 2 each of: pH 7.0 & pH 4.0, KCl	

9.3 Peristaltic Pump

Replacement pump motor, cover and tubing for Bluelab pH Controllers.

Quick and simple to replace when required.

9.4 Acid/Alkali Resistant Dosing Tube with Connectors

Replacement inlet/outlet tube - 13 foot / 4 meters.

For use with Bluelab pH Controllers and stock solution.

Dosing tube comes with barbs included to make replacement easy.

9.5 pH Probe KCl Storage Solution

The best solution to store and hydrate your Bluelab pH products. Bluelab pH Probe KCl Storage Solution increases response time and maximizes the life of Bluelab pH probes. Use the KCl solution monthly to hydrate the pH probe after use.

9.6 Bluelab limited warranty



The Bluelab pH Controller comes with a 2 year limited written warranty (6 months for pH probe). Proof of purchase required.

Bluelab Corporation Limited (Bluelab) provides a limited warranty under the following terms and conditions:

How Long Does Coverage Last?

Bluelab warrants the Bluelab pH Controller (Product) for a period of 24-months from date of purchase by original purchaser or consumer. Proof of purchase, to Bluelab satisfaction, is required for the warranty to be effective (store sales receipt for Product showing model number, payment, and date of purchase). This warranty is non-transferable and terminates if the original purchaser/consumer sells or transfers the Product to a third party.

What is Covered?

Bluelab warrants the Product against defects in material and workmanship when used in a normal manner, in accordance with Bluelab instruction manuals. If Bluelab is provided with valid proof of purchase (as defined above) and determines the Product is defective, Bluelab may, in its sole discretion either (a) repair the Product with new or refurbished parts, or (b) replace the Product with a new or refurbished Product.

Any part or Product that is replaced by Bluelab shall become its property. Further, if a replacement part or Product is no longer available or is no longer being manufactured, Bluelab may at its sole discretion replace it with a functionally equivalent replacement part or product, as an accommodation in full satisfaction of the warranty.

What is NOT covered?

This warranty does not apply to equipment, component or part that was not manufactured or sold by Bluelab and shall be void if any such item is installed on a Product. Further, this warranty does not apply to replacement of items subject to normal use, wear and tear and expressly excludes:

- Cosmetic damage such as stains, scratches and dents.
- Damage due to accident, improper use, negligence, neglect and careless operation or handling of Product not in accordance with Bluelab instruction manuals, or failure to maintain or care for Product as recommended by Bluelab.
- Damage caused by use of parts not assembled/installed as per Bluelab instructions.
- Damage caused by use of parts or accessories not produced or recommended by Bluelab®.
- Damage due to transportation or shipment of Product.
- Product repaired or altered by parties other than Bluelab® or its authorised agents.
- Product with defaced, missing or illegible serial numbers.
- Products not purchased from Bluelab or a Bluelab-authorised distributor or reseller.

How Do You Get Service?

To begin a warranty claim you must return the Product to the point of purchase with valid proof of purchase (as defined above). You can also return the Product to any Bluelab-authorised distributor or reseller, with valid proof of purchase.

Limitation of Liability & Acknowledgments

TO THE MAXIMUM EXTENT PERMITTED BY LAW, THIS WARRANTY AND THE REMEDIES SET OUT ABOVE ARE EXCLUSIVE AND IN LIEU OF ALL OTHER WARRANTIES, GUARANTEES AND REMEDIES (ORAL OR WRITTEN, EXPRESS OR IMPLIED).

EXCEPT AS PROVIDED IN THIS WARRANTY AND TO THE MAXIMUM EXTENT PERMITTED BY LAW, BLUELAB IS NOT RESPONSIBLE FOR SPECIAL, INCIDENTAL OR CONSEQUENTIAL LOSS OR DAMAGES, OR ANY OTHER LOSS OR DAMAGES RESULTING FROM SALE OR USE OF THE PRODUCT, OR BREACH OF WARRANTY, HOWEVER CAUSED, INCLUDING DAMAGES FOR LOST PROFITS, PERSONAL INJURY OR PROPERTY DAMAGE.

IT IS UNDERSTOOD AND AGREED BY CONSUMER UPON PURCHASE OF A PRODUCT THAT, EXCEPT AS STATED IN THIS WARRANTY, BLUELAB IS NOT MAKING AND HAS NOT MADE ANY EXPRESS OR IMPLIED WARRANTY OR OTHER REPRESENTATION REGARDING THE PRODUCT AND DISCLAIMS ANY WARRANTY OF MERCHANTABILITY OR FITNESS FOR A PARTICULAR PURPOSE TO THE EXTENT PERMITTED BY LAW. ANY WARRANTIES WHICH ARE IMPOSED BY LAW AND CANNOT BE DISCLAIMED ARE HEREBY LIMITED IN DURATION TO THE PERIOD AND REMEDIES PROVIDED IN THIS WARRANTY.

SOME JURISDICTIONS (STATES OR COUNTRIES) DO NOT ALLOW EXCLUSION OR LIMITATION FOR INCIDENTAL OR CONSEQUENTIAL DAMAGES, OR LIMITATION ON HOW LONG AN IMPLIED WARRANTY LASTS, SO THE ABOVE LIMITATION OR EXCLUSION MAY NOT BE APPLICABLE.

IF ANY PROVISION OF THIS WARRANTY IS JUDGED TO BE ILLEGAL, INVALID OR UNENFORCEABLE, THE REMAINING PROVISIONS OF THE WARRANTY SHALL REMAIN IN FULL FORCE AND EFFECT.

Governing Law; Authority

This warranty is governed by the laws of the state of country where Product is purchased, without regard to its choice of law principles. Except as allowed by law, Bluelab does not limit or exclude other rights a consumer may have with regard to the Product. No Bluelab distributor, employee or agent is authorised to modify, extend, or otherwise change the terms of this warranty.

Register your product online at bluelab.com/product-registration

10. Get in touch



If you need assistance or advice - we're here to help you.

Email: support@bluelab.com



Looking for specifications or technical advice?

Visit us online at bluelab.com or facebook.com/bluelabofficial



Bluelab Corporation Limited

8 Whiore Avenue, Tauriko Business Estate

Tauranga 3110, New Zealand

Published 23 November 2023

© Copyright 2023, all rights reserved, Bluelab Corporation Limited