

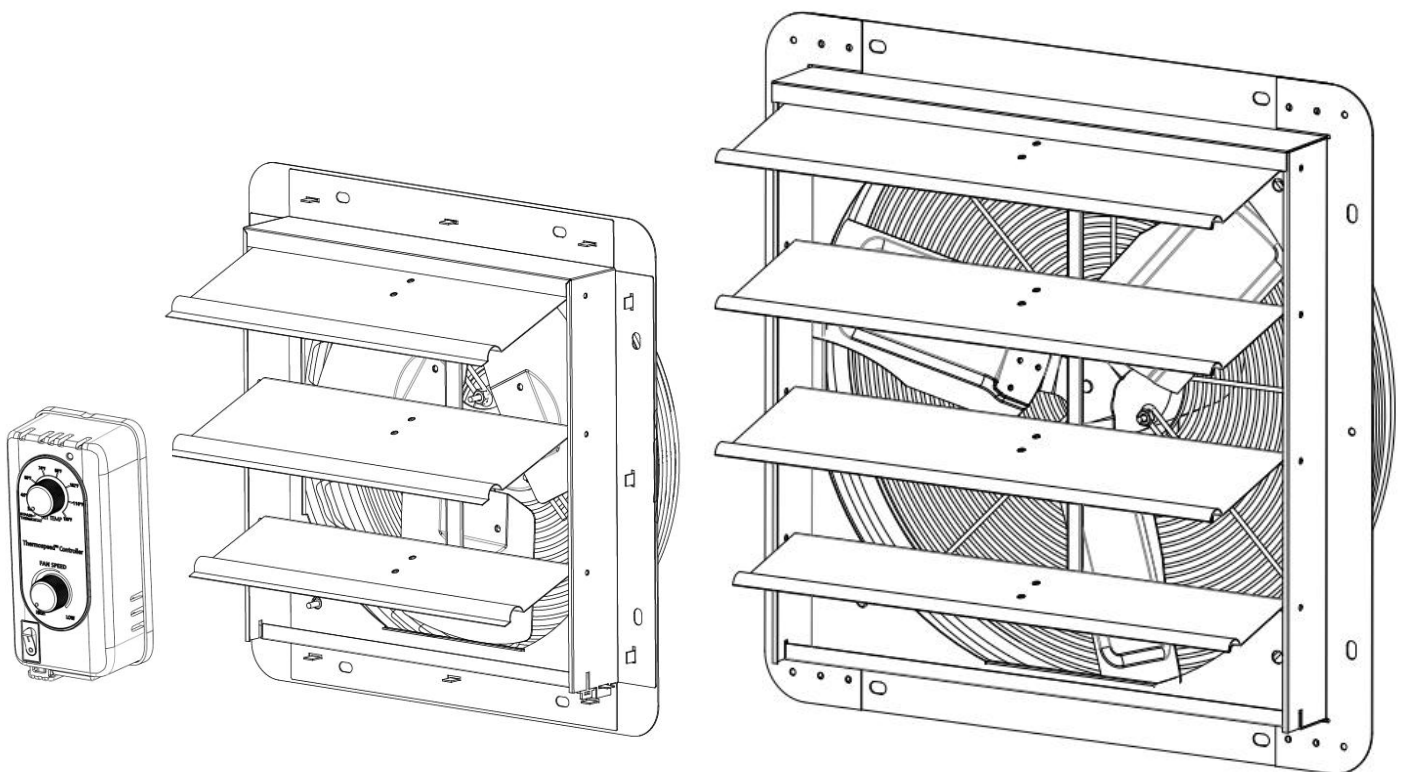

SHUTTER MOUNTED EXHAUST FAN WITH THERMOSPEED (™) CONTROLLER



Models: ILG8SF10V-ST/ILG8SF12V-ST/ILG8SF16V-ST
ILG8SF18V-ST/ILG8SF20V-ST

OWNER'S MANUAL

**PLEASE READ AND SAVE THESE
INSTRUCTIONS**



PLEASE READ AND SAVE THESE INSTRUCTIONS. READ CAREFULLY BEFORE ATTEMPTING TO ASSEMBLE, INSTALL, OPERATE, OR MAINTAIN THE PRODUCT DESCRIBED. PROTECT YOURSELF AND OTHERS BY OBSERVING ALL SAFETY INFORMATION. FAILURE TO COMPLY WITH INSTRUCTIONS COULD RESULT IN PERSONAL INJURY AND/OR PROPERTY DAMAGE! RETAIN INSTRUCTIONS FOR FUTURE REFERENCE.

BEFORE YOU BEGIN



WARNING

Installation, trouble shooting, and replacement of parts are to be performed only by authorized service technicians.

Electrical Requirements:

- The motor amperage and voltage ratings must be checked for compatibility to supply voltage prior to final electrical connection. Please refer to the motor's nameplate label.
- Wiring must conform to local, state, and national codes.

Tools / Materials Needed:(Not Included)

- Mounting Fasteners (8)
- Sealant or Caulk
- Regular Screwdriver Set

UNPACKING

Contents:

- Shutter Mounted Exhaust Fan
- Fan control (ILG8SFST)
- Owner's Manual

Inspect:

- After unpacking fan, carefully inspect for any damage that may have occurred during transit. Check for loose, missing, or damaged parts.
- Check all bolts, screws, set-screws, etc. for looseness that may have occurred during transit. Tighten as needed. Rotate propeller by hand to ensure it turns freely.
- See General Safety Instructions on page 3, and Cautions and Warnings as shown.

GENERAL SAFETY INSTRUCTIONS

1. Do not depend on any switch as the sole means of disconnecting power when installing or servicing the fan.
2. Always disconnect, lock-out, and tag-out power source before installing or servicing. Failure to disconnect power source can result in fire, shock, or serious injury.
3. Motor will restart without warning after thermal protector trips. Do not touch operating motor; it may be hot enough to cause injury.
4. Do not place body parts or objects in fan or motor openings while motor is connected to the power source.
5. All electrical connections should be made by a qualified electrician.
6. These utility exhaust fans are for general purpose exhaust applications only. Do not use these exhaust fans in an area where corrosive or explosive materials may be found.
7. Follow all local and state/provincial electrical and safety codes in the United States and Canada, as well as the National Electrical Code (NEC) and the Occupational Safety and Health Act (OSHA) in the United States, and the Canadian Electric Code (CEC) in Canada.
8. Always disconnect power source before working on or near a motor or its connected load.
9. Protect the power cable from coming in contact with sharp objects.
10. Do not kink or create tight bends in the power cable and never allow the cable to come in contact with oil, grease, hot surfaces, or chemicals.
11. Make certain that the power source conforms to the requirements of your specific exhaust fan model. The fan frame and motor must be electrically grounded to a suitable electrical ground, such as a grounded water pipe or ground wire system.
12. To reduce the risk of injury to persons, please observe the following: In the United States, OSHA compliant guards are required when fan is installed within 7 feet of the floor or working level. In Canada, CSA compliant guards are required when fan is installed below 2.5 meters (8.2 feet) above the floor or grade level.
13. Suitable for use with specific solid-state speed controls.

INSTALLATION INSTRUCTIONS

1. The unit should be securely mounted in a rigid framework.
NOTE: Allowing the fan frame to flex or move will result in excess vibrations, which may cause possible premature motor, propeller, or shutter failure.
2. Install any auxiliary components such as thermostats, switches, or speed controls.
3. Connect power to the motor using an approved wiring method.
 Refer to the following wiring diagram.

⚠ Fan frame and motor must be securely and adequately grounded to a suitable electrical ground, such as a ground water pipe or ground wiring system.

Wiring Diagram

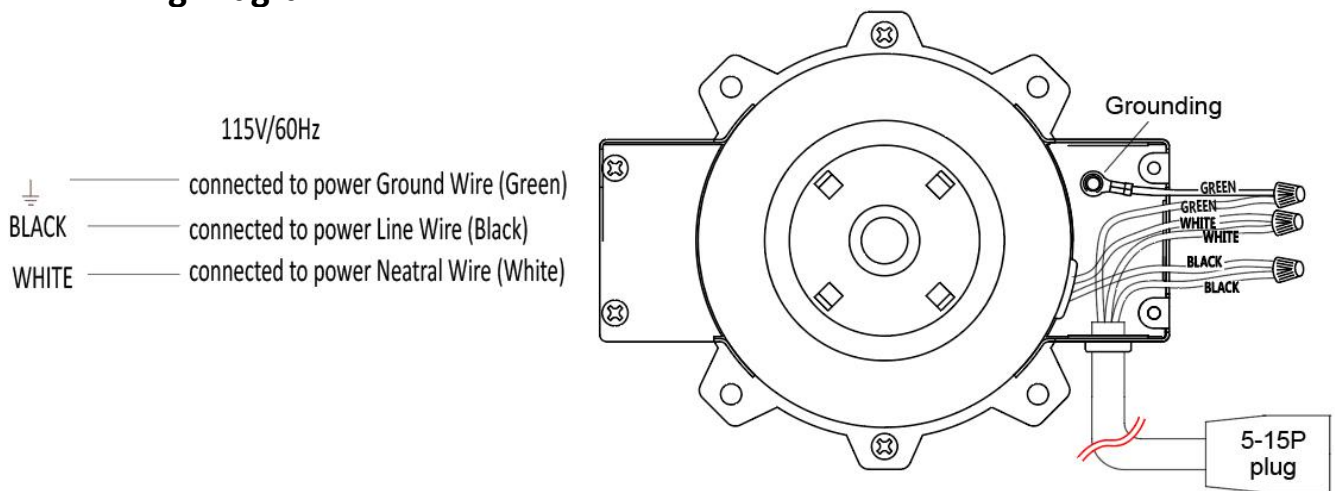

Figure 1: Wiring in Junction Box - for ILG8SF10V-ST, ILG8SF12V-ST

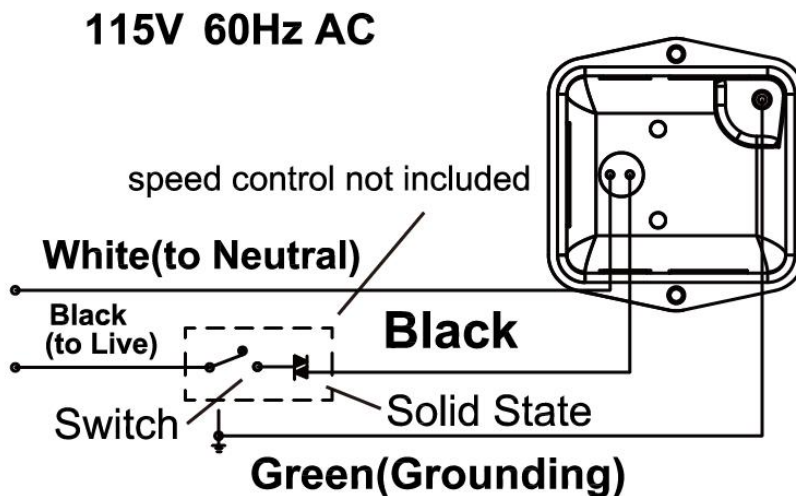
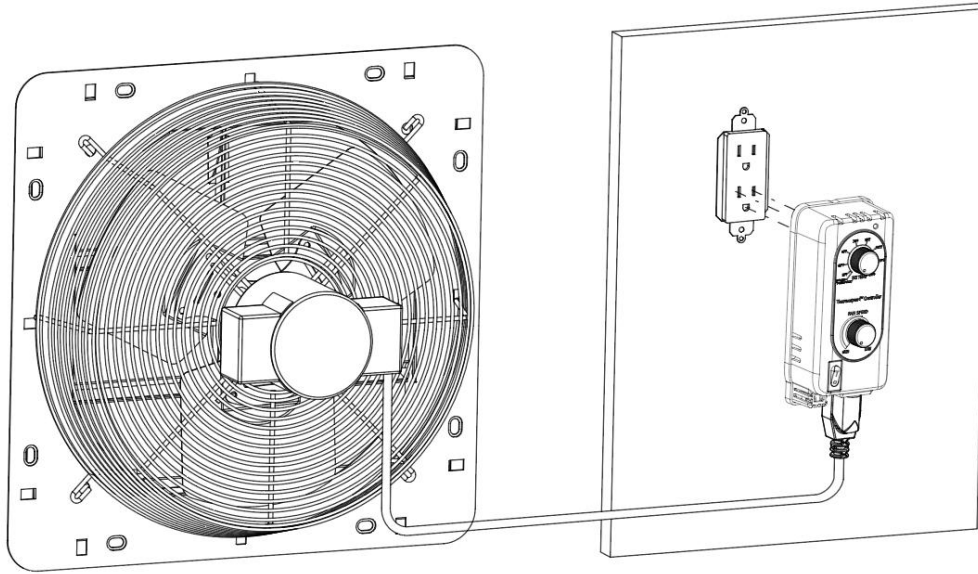

Figure 2: Wiring Diagram - for ILG8SF16V, ILG8SF18V, ILG8SF20V-1

Installation Diagram for ILG8SF10V-ST, ILG8SF12V-ST



Shutter Fan Models:
ILG8SF12V-ST
ILG8SF10V-ST

(Fan Control
Model: ILG8SFST)

Installation Diagram for ILG8SF16V, ILG8SF18V, ILG8SF20V-1

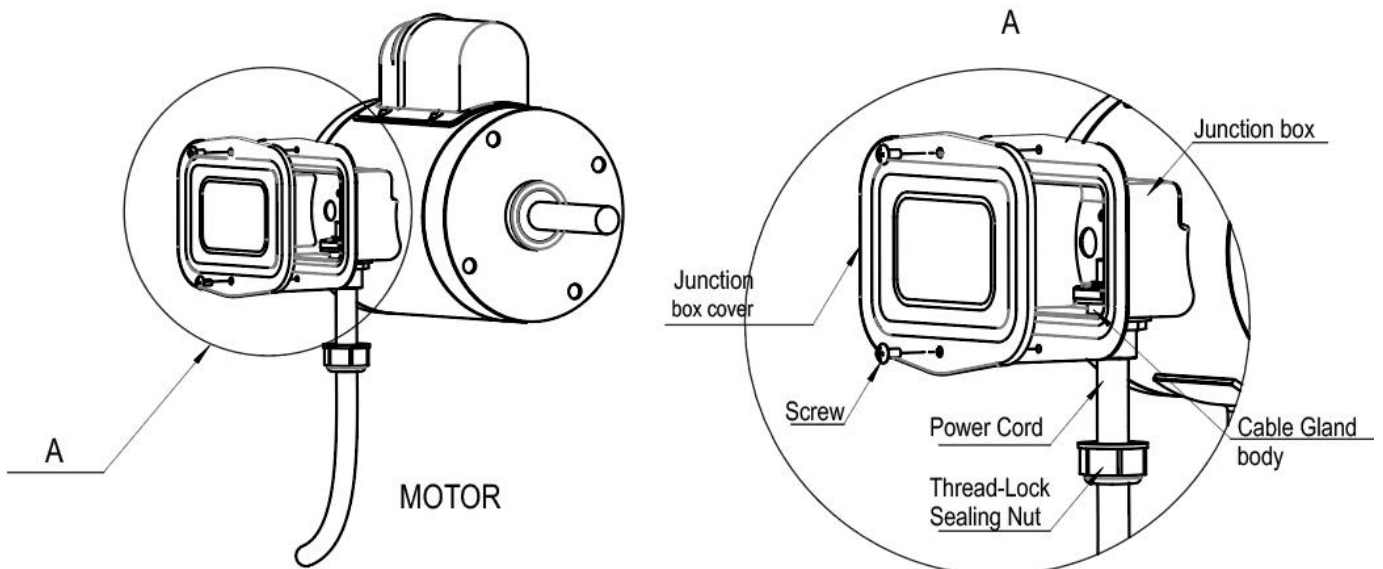



Figure A

1. Remove the 2 screws from the Junction Box. Open the Junction Box Cover.
2. Unscrew the Thread-Lock Sealing Nut.
3. Thread the supplied power cord through the Thread-Lock Sealing Nut and Cable Gland body in turn.
4. Follow the wiring diagram (Figure B) for proper connections.

115V/60Hz

-  connected to power Ground Wire (Green)
- BLACK connected to power Line Wire (Black)
- WHITE connected to power Neutral Wire (White)

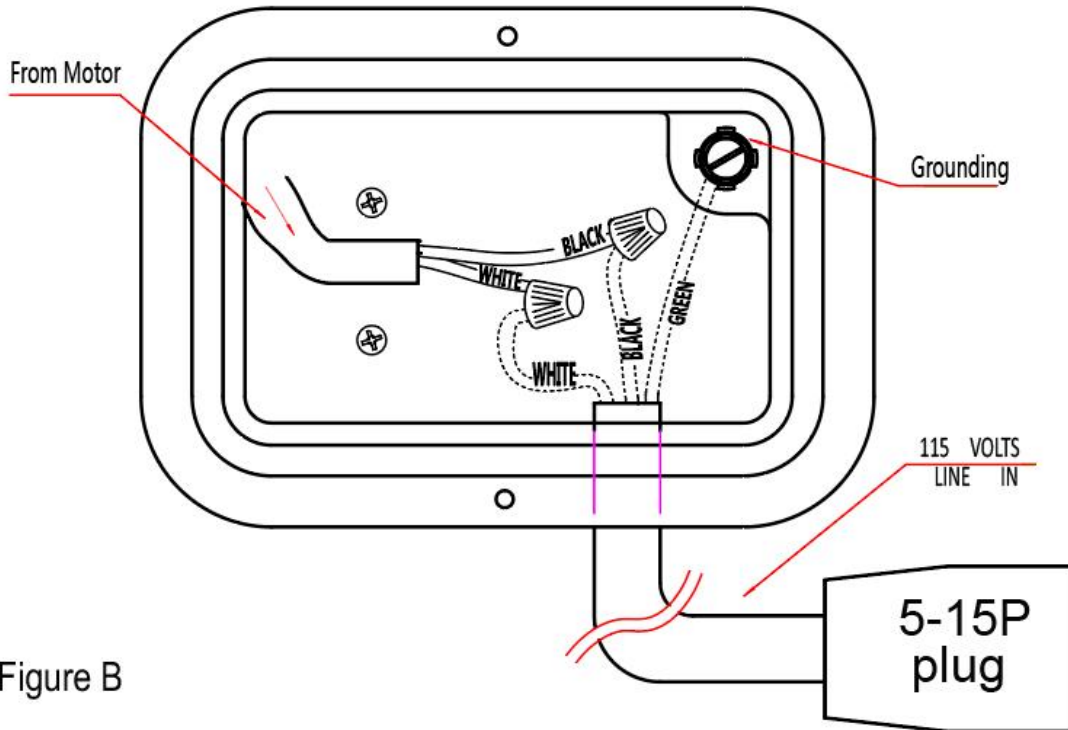
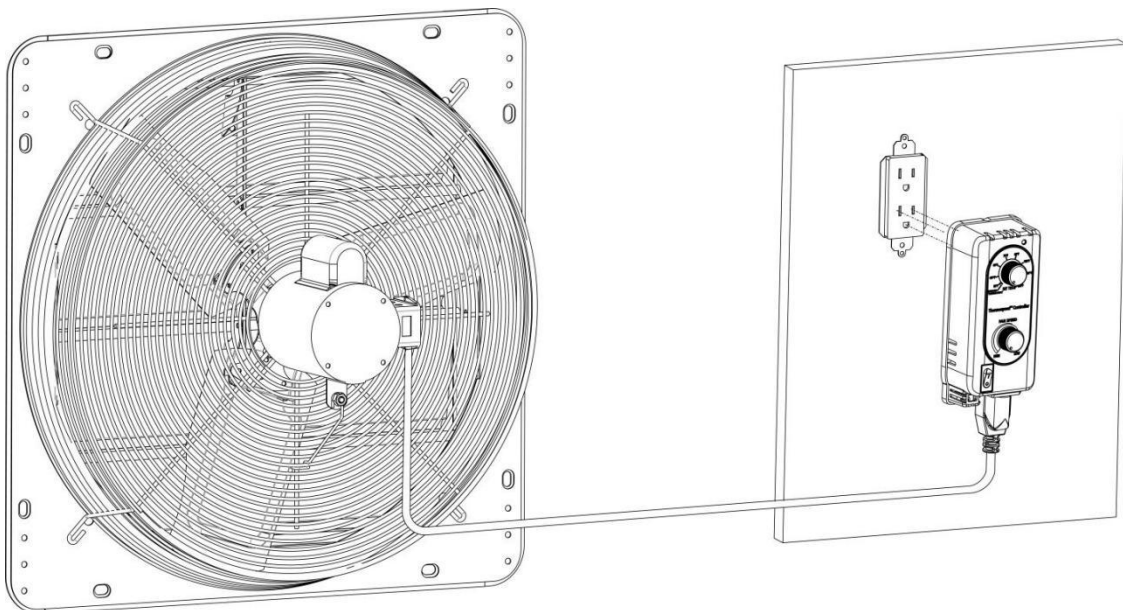

Figure B

5. Tighten the Thread-Lock Sealing Nut.
6. Thread-Lock Sealing Nut tightening requirements: No movement of the power cord under a maximum tension of 36 LBS.
7. Install the junction box cover.
8. Insert the plug into the Fan Control (ILG8SFST).



Shutter Fan Models:
ILG8SF16V
ILG8SF18V
ILG8SF20V-1

Fan Control Model:
ILG8SFST

GENERAL SPECIFICATIONS

Power source	115V, 60Hz
Mounting Position	Vertical
Frame Material	Galvanized Steel
Shutter Blade Material	Aluminum Alloy
Propeller Material	Aluminum Alloy and Galvanized Steel

Dimensions (Inches)

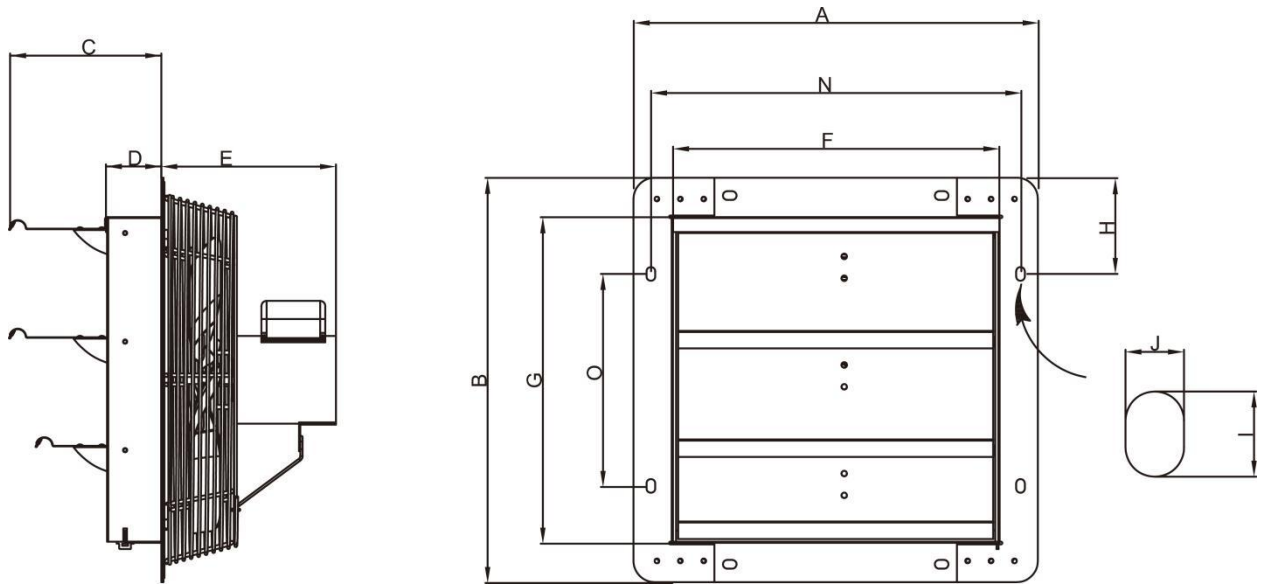

Figure 3

MODEL	Prop. Dia.	A	B	C	D	E	N	G	F	O	H	J	I	Suggested wall opening (Sq)
ILG8SF10V-ST	10"	13"	13"	5 3/4"	2"	5 5/8"	11 21/32"	10"	10"	6"	3 17/32"	9/32"	1/2"	10 1/2"
ILG8SF12V-ST	12"	15"	15"	5 3/4"	2"	5 5/8"	13 5/8"	12 1/8"	12 1/8"	8"	3 1/2"	9/32"	1/2"	13"
ILG8SF16V	16"	18 29/32"	18 29/32"	5 3/4"	2"	7 7/8"	17 3/4"	16"	16"	11 29/32"	3 17/32"	9/32"	1/2"	17"
ILG8SF18V	18"	21"	21"	5 3/4"	2"	8 3/4"	19 11/16"	18"	18"	14"	3 17/32"	9/32"	1/2"	19"
ILG8SF20V-1	20"	23"	23"	5 3/4"	2"	10"	21 25/32"	20"	20"	16"	3 17/32"	9/32"	1/2"	21"

Performance

MODEL	Prop. Dia.	Nom. HP	Amps	Nom. RPM	Bearing Type	Sones @ 0.0" SP @ 5'	CFM Air Delivery @ Static Pressure Shown		
							0.00"	0.125"	0.25"
ILG8SF10V-ST	10"	1/20	0.60	1650	Sleeve	6.19	820	480	350
ILG8SF12V-ST	12"	1/20	0.60	1650	Sleeve	5.9	960	490	360
ILG8SF16V	16"	1/20	0.85	1550	Ball	6.39	1200	416	180
ILG8SF18V	18"	1/15	0.85	1075	Ball	7.4	1736	1108	N/A
ILG8SF20V-1	20"	1/5	2.2	980	Ball	6.5	3000	1900	350

OPERATING INSTRUCTIONS

1. Keep the area free of objects that could impede air flow on both the intake and exhaust side of fan.
2. For proper exhaust operation, a window, door, or louver should be opened for fresh air intake on the opposite side of the area to be ventilated.
3. Turn the fan ON; the shutter will open automatically. When the unit is turned OFF, the shutter will close.
4. Speed controllable units are designed to operate at a minimum of fifty percent line voltage.

FAN CONTROL (ILG8SFST)

Control Descriptions

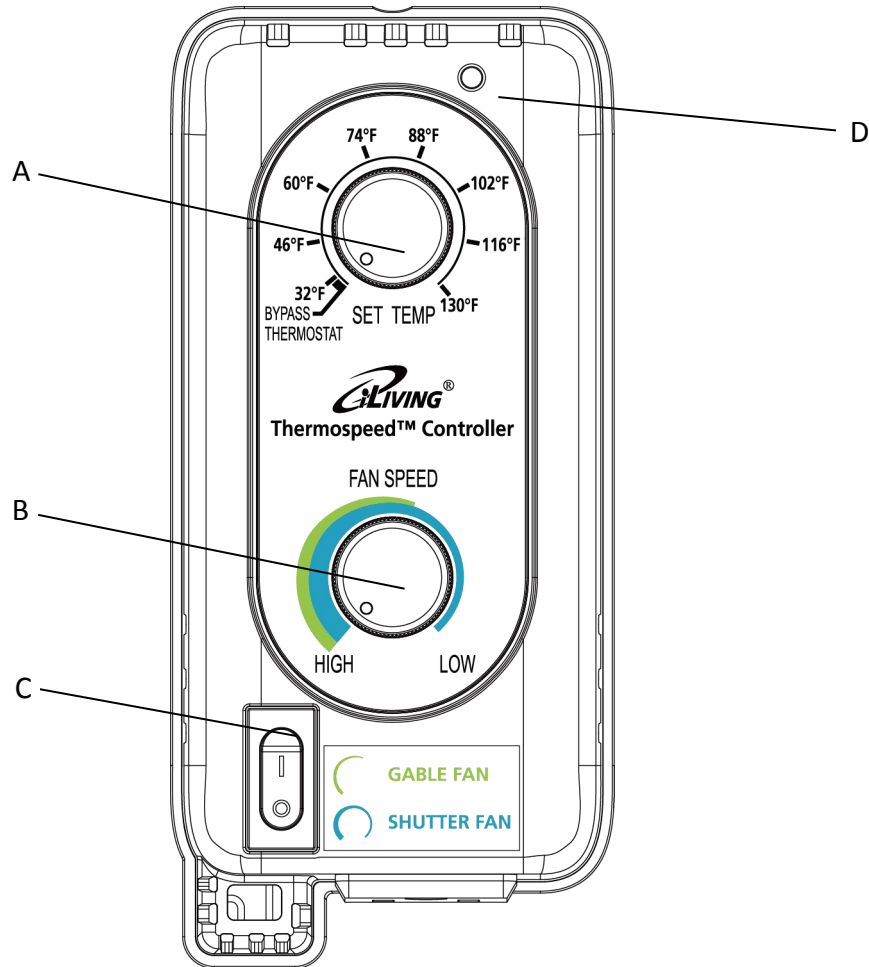

Name and Function

A. Set Temp Knob
B. Fan Speed Knob

C. Power Switch
D. Power LED Display

Operation Instruction

Power control:

Power Switch

To start the controller, switch the power button to **I** position.

To turn off the controller, switch the power button to **O** position.

Operating mode

Fan speed control:

1. Adjust the fan speed according to the FAN SPEED knob  , from large to small.
2. Upon start up, fan will run at full speed for 4 seconds as start up sequence, and then run at the set speed.

Temperature control:

1. Adjust the setting temperature range from 32 degrees F to 130 degrees F using SET



TEMP knob

2. When the room temperature drops to \leq the set temperature -2~3 degree F, the fan stops running. When the room temperature rises to \geq the set temperature+ 2~3 degree F, the fan will turn on.
3. Turn the SET TEMP knob to the red line area "BYPASS THERMOSTAT", to by pass temperature control; fan will run continuously regardless of temperature.

MAINTAINANCE

1. Disconnect power source before servicing.
2. Periodically clean off accumulated dirt from the propeller, guard, motor, and shutter.



Do not depend on any switch as the sole means of disconnecting power when installing or servicing. If power disconnect is not visible, utilize OSHA Lock out/Tag out procedure.



Failure to do so may result in fatal electrical shock. Employ proper lock-out/tag-out procedures when performing maintenance.

TROUBLESHOOTING

Symptom	Possible Cause(s)	Solution
Excessive noise	Dry motor bearings	Re-lubricate motor bearings as per instructions or replace motor.
	Loose propeller	Tighten set screws on propeller hub.
	Bent or damaged propeller	Replace propeller
	Loose guard assembly or motor fasteners.	Tighten as required to 15-20 lbs. per inch.
Fan inoperative	Blown fuse or open circuit breaker	Replace fuse or reset circuit breaker
	Defective motor	Replace motor
	Switch in OFF position	Turn switch ON
Insufficient air flow	Blocked intake or exhaust opening	Clear intake and exhaust openings of any obstructions. Clean motor, guard, propeller, and shutter assembly. Increase the opening of the fresh air intake.
	Low voltage	Check electrical wiring.
	Speed control set too low	Increase speed with controller

Warranty Information

Register your product at our website:



Or visit iLivingUSA.com/register-product

Feedback

Love it? Help us make the product more for you.



Let us know with a customer review.

Please visit: <https://www.amazon.com/review/review-your-purchases#>

At iLiving USA, we are committed to bringing top quality products to our customers.

iLIVING USA
860 Mahler Road,
Burlingame, CA 94010
Tel: 1-800-317-1688
Email: service@ilivingusa.com



Like us on Facebook: <https://www.facebook.com/ilivingusa/>



Follow us on Twitter: @iLIVINGUSA

Check out our website: www.ilivingusa.com