

NUC 220NX

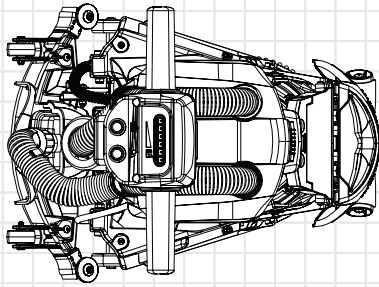

Service Engineer Exploded Drawings

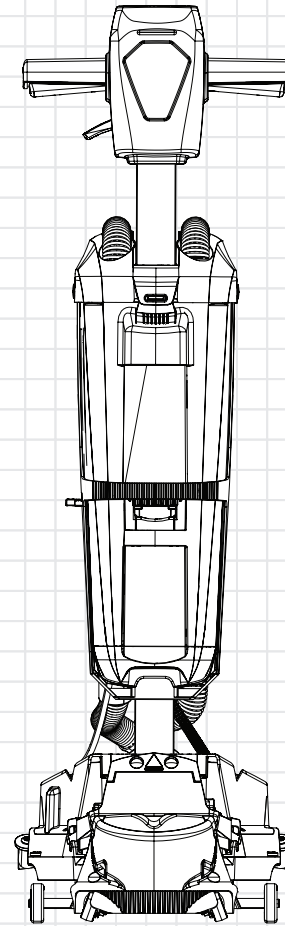
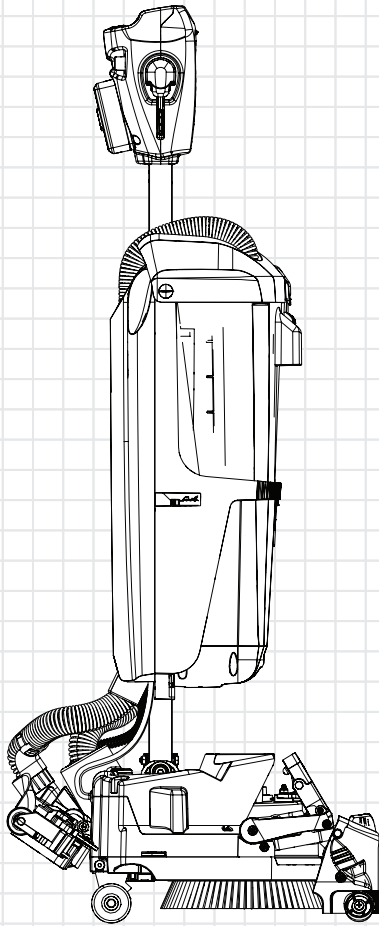

DISCLAIMER:

These drawings are for part order reference only and intended for service engineers use.

The installation of Genuine Numatic spare parts should only be executed by Certified Numatic service engineers who specialised and familiar with all relevant safety regulations.

Numatic International Ltd do not accept responsibility or liability for any loss or damage to property or person if repairs or servicing of products are carried out by non-certified persons.

Specifications and parts are subject to change without notice.

EXENCIÓN DE RESPONSABILIDAD:**ES**

Estos esquemas solo se muestran como referencia para pedir piezas y para su uso por parte de ingenieros de mantenimiento.

La instalación de recambios originales de Numatic solo deben realizarla los ingenieros de mantenimiento homologados de Numatic que estén especializados y familiarizados con las normativas de seguridad pertinentes.

Numatic International Ltd no acepta la responsabilidad de cualquier pérdida o daño a la propiedad o a las personas si las reparaciones o el mantenimiento de los productos se llevan a cabo por personas sin certificación.

Las especificaciones y piezas están sujetas a cambios sin previo aviso.

CLAUSE DE NON-RESPONSABILITÉ:**FR**

Ces schémas sont fournis à titre de référence de commande de pièces uniquement et sont destinés aux techniciens de maintenance.

L'installation de pièces de rechange Numatic d'origine doit être effectuée uniquement par des techniciens de maintenance Numatic certifiés spécialisés et familiarisés avec toutes les règles de sécurité applicables.

Numatic International Ltd décline toute responsabilité en cas de perte ou de dommage matériel ou personnel si des réparations ou l'entretien des produits sont effectués par des personnes non certifiées.

Les spécifications et les pièces sont susceptibles d'être modifiées sans préavis.

Numatic International Spare Parts

Model No: NCC220 TOP LEVEL ASSEMBLY

NB: FOR WIRING SEE DRAWING: WD-077?

917371, 918989, 920531
DRAWING: DRW-42246 ISS-A06
10/04/2025

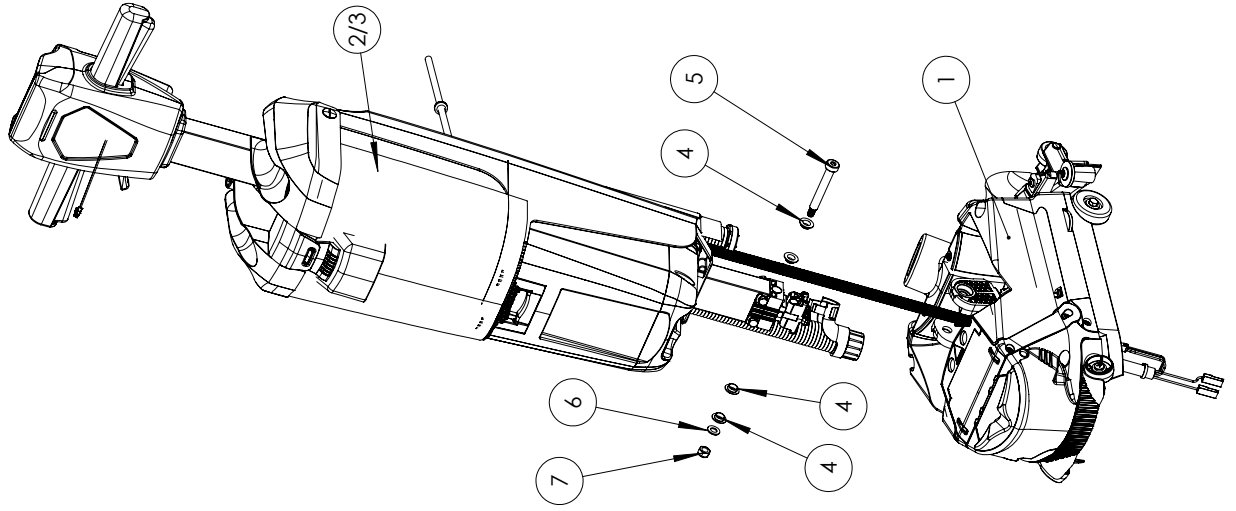

Numatic International Spare Parts

Model No: NCC220 TOP LEVEL ASSEMBLY

ITEM NO.	Item_No	DESCRIPTION	COMMENTS	QTY.
1	917881	NCC220 DECK ASSY		1
2	920530	MID SECTION ASSEMBLY - HOURS METER	920531 ONLY	1
3	918988	MIDSECTION ASSEMBLY - TELEMATICS	918989 ONLY	1
4	208312	IGUS BEARING (GFM 101205)		4
5	920813	M8 X 10 X 65MM LONG HEX SOCKET SHOULDER BOLT		1
6	219578	M8 FORM A STAINLESS STEEL WASHER		1
7	219639	M8 STAINLESS STEEL NYLON INSERT NUT		1

Numatic International Spare Parts

Model No: HANDLE SUB-ASSEMBLY

NB: FOR WIRING SEE DRAWING: WD-07??

917984, 918983, 920527
DRAWING: DRW-42241 ISS:A07
11/02/2025

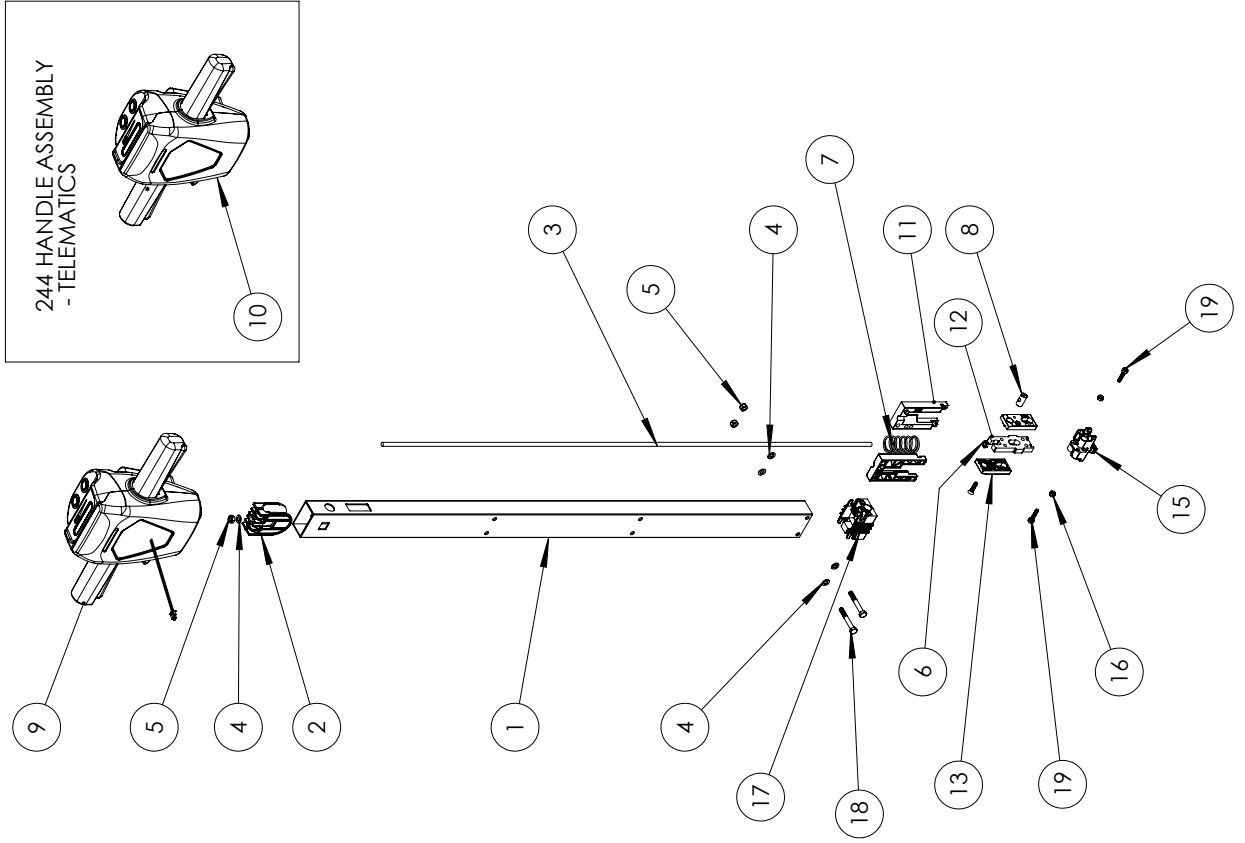

Numatic International Spare Parts

Model No: HANDLE SUB-ASSEMBLY

ITEM NO.	Item_No	DESCRIPTION	COMMENTS	QTY.
1	918197	HANDLE STEM PAINTED BLACK		1
2	910730	HANDLE RELEASE SLIDER		1
3	910882	HANDLE LOCKING ROD		1
4	219870	M6 FORM A WASHER STAINLESS STEEL		5
5	219642	M6 STAINLESS STEEL NYLON INSERT HALF NUT		3
6	219099	M6 HALF NUT		1
7	208782	SPRING (C5517490)		1
8	911814	M6 X 20MM CROSS DOWEL BARREL NUT Z/PL		1
9	919505	244 HANDLE ASSEMBLY - HOURS METER	920528 ONLY	1
10	915763	244 HANDLE ASSEMBLY - TELEMATICS	918983 ONLY	1
11	917814	HANDLE GUIDE MOULDING		2
12	917981	LOCKING PIN CENTRAL PIN		1
13	917815	HANDLE ROLL LATCH		2
14	905558	M5 X 20MM LONG POZI PAN COUNTERSUNK SCREW ST/ST		2
15	917818	REMOVABLE LOCKING PIN		1
16	219633	M5 STAINLESS STEEL NYLON INSERT NUT		4
17	918921	YOKE PIVOT BRACKET		1
18	219896	M6 X 45MM LONG HEXAGONAL STAINLESS STEEL BOLT		2
19	219820	M5 X 20MM LONG SOCKET CAP SCREW		2

Numatic International Spare Parts

Model No: MID SECTION ASSEMBLY

NB: FOR WIRING SEE DRAWING: WD-07??

916938, 918988, 920530

DRAWING: DRW-41493 ISS:A04
11/02/2025

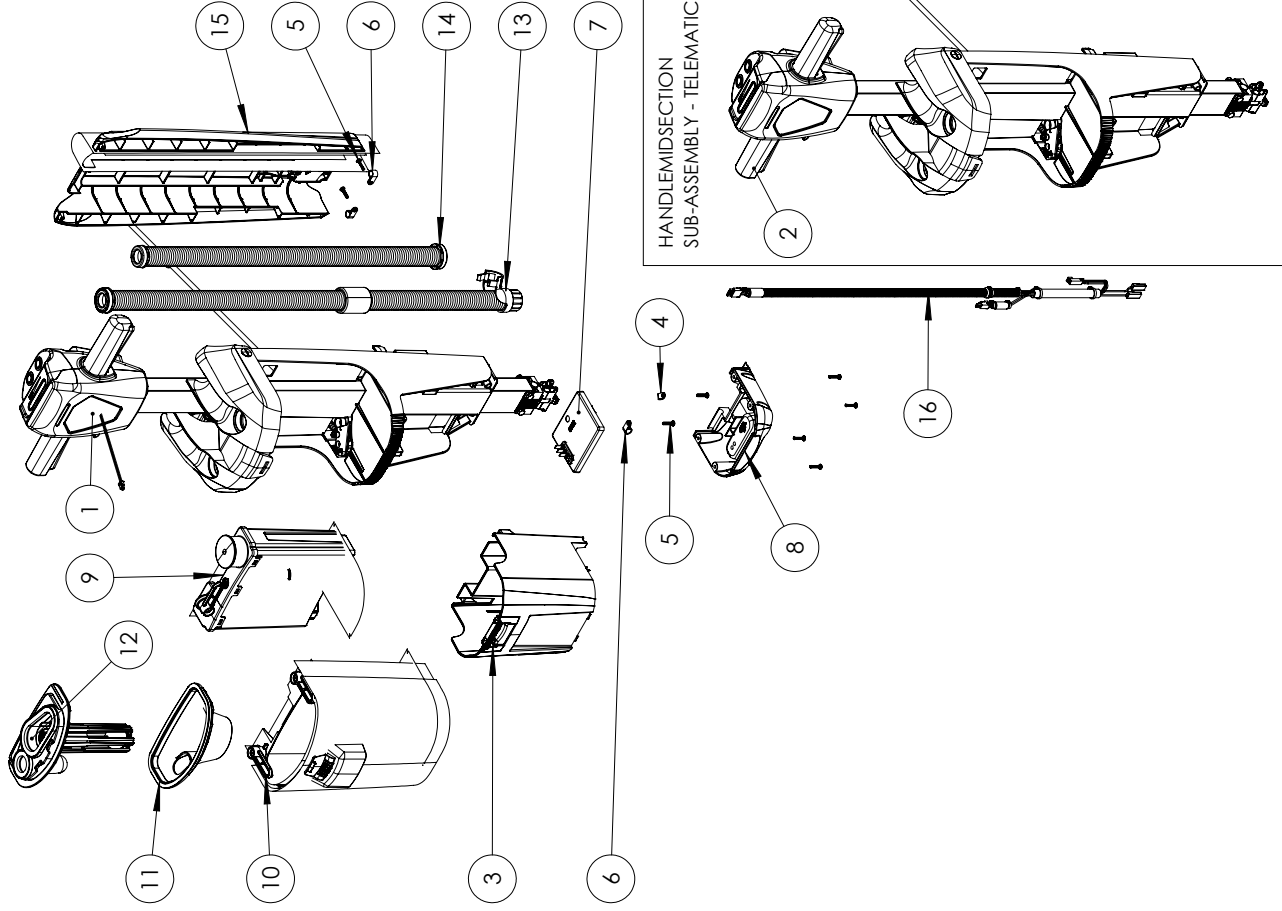

Numatic International Spare Parts

Model No: MID SECTION ASSEMBLY

ITEM NO.	PART NO.	DESCRIPTION	COMMENTS	QTY.
1	920528	HANDLE AND MID SECTION SUB-ASSEMBLY - HOURS METER	920530 ONLY	1
2	918987	HANDLE MIDSECTION SUB-ASSEMBLY - TELEMATICS	918988 ONLY	1
3	916923	BATTERY COMPARTMENT SUB-ASSEMBLY		1
4	226050	CABLE CLAMP (WHITE P CLIP)		1
5	219568	NO8.3/4 INCH LG.POZI-PAN.SCREW.STAINLESS STEEL.PLA.SITE	Torque to 2.6 Nm	8
6	219393	P CLIP		3
7	910930	CSD CONTROL PCB ASSEMBLY		1
8	916779	BATTERY COMPARTMENT - BASE MOULDING		1
9	916924	CLEAN TANK SUB-ASSEMBLY		1
10	916926	WASTE TANK SUB-ASSEMBLY		1
11	916764	WASTE TANK BAFFLE AND SEAL OVERMOULD		1
12	916927	WASTE TANK SEPARATOR AND SHUT OFF ASSY		1
13	917156	HOSE 800MM LONG 32.8MM OD 24MM ID COMPLETE WITH END FITTINGS & POSITIONING COLLAR		1
14	916891	HOSE 600MM LONG 32.8MM OD 24MM ID COMPLETE WITH END FITTINGS		1
15	916936	REAR COVER ASSY		1
16	916010	LOOM ASSEMBLY.4CRT		1

Numatic International Spare Parts

Model No: NCC220 DECK ASSY

NB: FOR WIRING SEE DRAWING: WD-07??

917881
DRAWING: DRW-41944 ISS:A06
09/04/2025

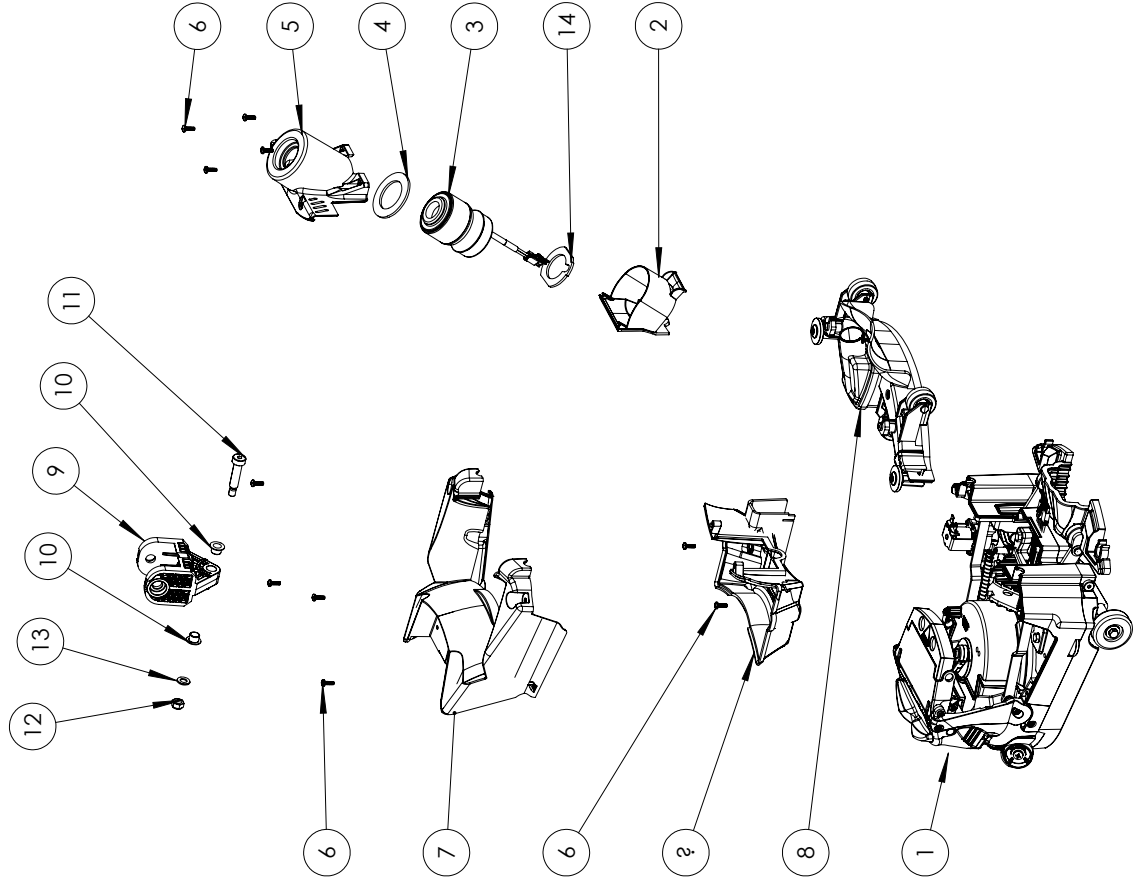

Numatic International Spare Parts

Model No: NCC220 DECK ASSY

ITEM NO.	Item_No	DESCRIPTION	COMMENTS	QTY.
1	917974	DECK BUILD STAGE 3		1
2	917400	VAC MOTOR POD		1
3	917711	BL05078-ID036-01 - KEJI - 36VDC 100W BYPASS MOTOR ASSEMBLY C/W 100MM LONG LEAD		1
4	917397	VAC MOTOR GASKET		1
5	917391	VAC MOTOR SHELL		1
6	219569	No8 X 1/2 INCH LONG POZI PAN STAINLESS STEEL PLASTIC SCREW	Torque to 2.6 Nm	10
7	917392	TOP SHELL		1
8	917902	325MM SQUEEGEE ASSEMBLY		1
9	917636	DIE CAST YOKE		1
10	208331	IGUS BEARING (GFM 101209)		2
11	917673	M8 X 10 X 35 LG SHOULDER BOLT	Torque to 10 Nm	1
12	219639	M8 STAINLESS STEEL NYLON INSERT NUT		1
13	219578	M8 FORM A STAINLESS STEEL WASHER		1
14	918948	VAC MOTOR GASKET BOITOM		1
15	918657	UPSTAND SURROUND SHELL		1

Numatic International Spare Parts

Model No: DECK STAGE 1 ASSY (UPSTANDS)

NB: FOR WIRING SEE DRAWING: WD-0777

917957

DRAWING: DRW-41940 ISS:A06
07/04/2025

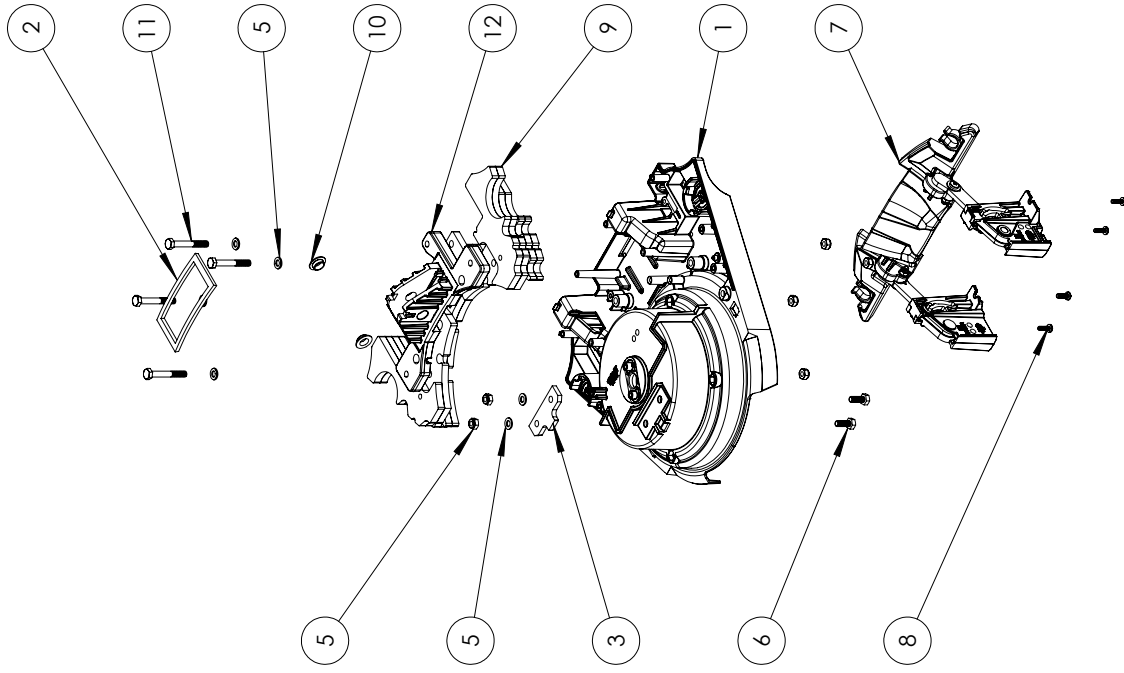

Numatic International Spare Parts

Model No: DECK STAGE 1 ASSY (UPSTANDS)

ITEM:	PART No:	Description	COMMENTS	QTY.
1	917374	DECK BASE		1
2	917381	UPSTAND GASKET		1
3	917289	LIFT HOOK LATCH PLATE		1
5	219642	M6 STAINLESS STEEL NYLON INSERT HALF NUT		6
5	219870	M6 FORM A WASHER STAINLESS STEEL		6
6	219719	M6 X 16MM LONG HEXAGONAL STAINLESS STEEL HEAD BOLT	Torque to 8.5 Nm	2
7	917956	SQUEEGEE LIFT ASSY		1
8	219569	No8 X 1/2 INCH LONG POZI PAN STAINLESS STEEL PLASTIC SCREW	Torque to 2.6 Nm	4
9	917908	DECK WEIGHTS WELDED ASSEMBLY		1
10	208312	IGUS BEARING (GFM 101205)		2
11	219896	M6 X 45MM LONG HEXAGONAL STAINLESS STEEL BOLT		4
12	917571	DIE CAST UPSTANDS		1

Numatic International Spare Parts

Model No: DECK STAGE 2 ASSY (MOTOR & REAR AXEL)

917964
DRAWING: DRW-41941 ISS:A05
10/04/2025

NB: FOR WIRING SEE DRAWING: WD-0???

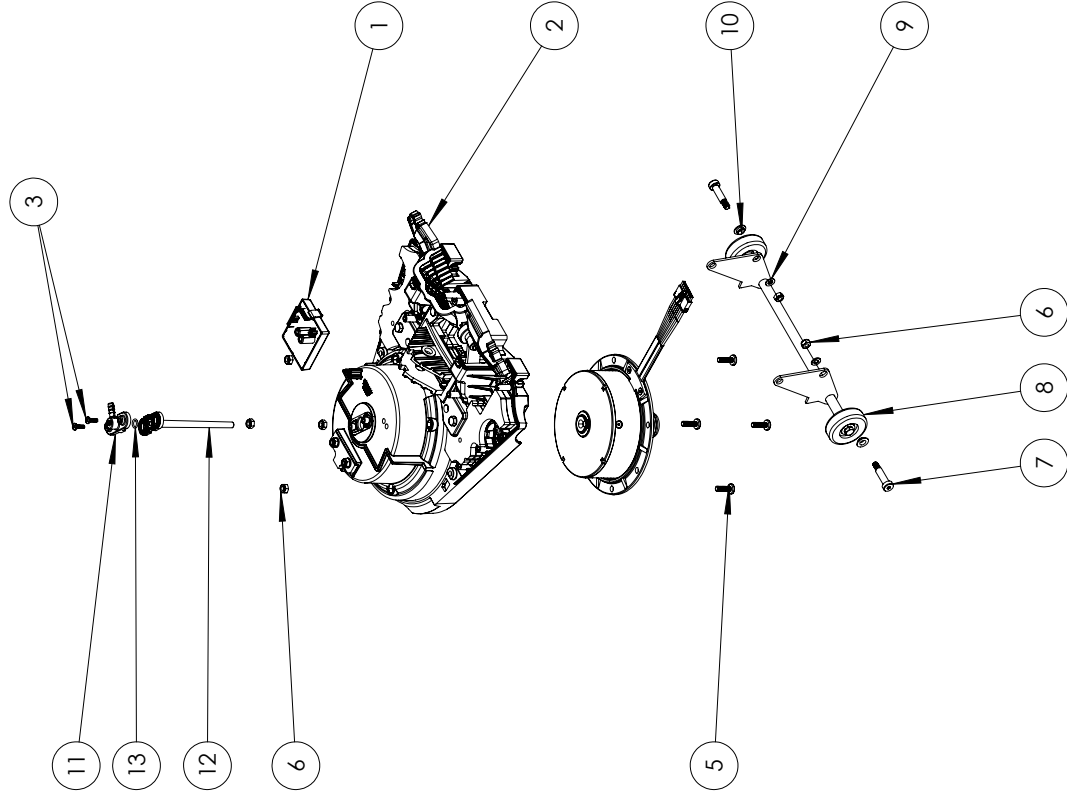

Numatic International Spare Parts

Model No: DECK STAGE 2 ASSY (MOTOR & REAR AXEL)

ITEM NO.	PART NO.	DESCRIPTION	COMMENTS	QTY.
1	916659	XR 36V BLDC MOTOR CONTROLLER (CLOCKWISE)		1
2	917957	DECK STAGE 1 ASSY (UPSTANDS)		1
3	219569	N68 X 1/2 INCH LONG POZI PAN STAINLESS STEEL PLASTITE SCREW	Torque to 2.6 Nm	2
4	917885	MOTOR & CHUCK ASSY		1
5	219701	M6 X 20MM LONG POZI PAN STAINLESS STEEL SCREW	Torque to 7 Nm	4
6	219642	M6 STAINLESS STEEL NYLON INSERT HALF NUT		6
7	918633	M6 X 8MM X 25MM LONG HEX SOCKET SHOULDER BOLT	Torque to 2.6 Nm	2
8	917963	MAIN WHEEL ASSY		1
9	219870	M6 FORM A WASHER STAINLESS STEEL		2
10	917960	FLANGE BEARING 8MM BORE 10MM HOUSING 4MM DEPTH		2
11	917783	90 DEGREE SOLUTION HOSE CONNECTOR		1
12	917292	SOLUTION FEED SPIGOT		1
13	917899	NITRILE O RING SIZE TO BS1806-011		1

Numatic International Spare Parts

Model No: DECK STAGE 3 ASSY (REAR SHELL & V LIFT)

917974
DRAWING: DRW-41943 ISS:A06
10/04/2025

NB: FOR WIRING SEE DRAWING: WD-07??

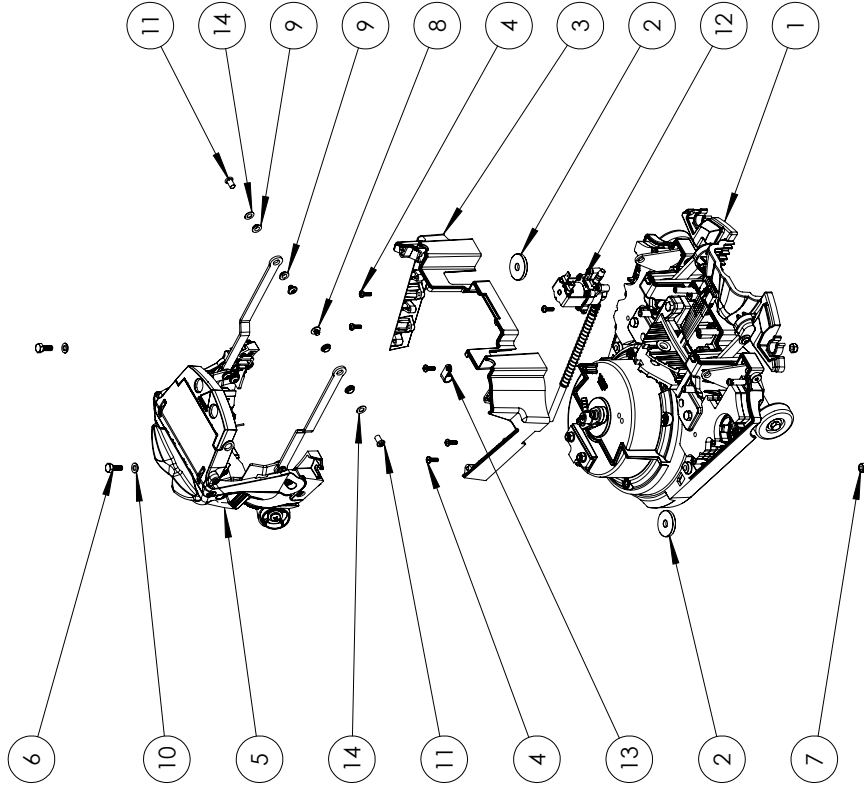

Numatic International Spare Parts

Model No: DECK STAGE 3 ASSY (REAR SHELL & V LIFT)

ITEM NO.	PART NO.	DESCRIPTION	COMMENTS	QTY.
1	917964	DECK BUILD STAGE 2		1
2	237266	BUFFER WHEEL		2
3	917399	REAR SHELL BASE		1
4	219569	N08 X 1/2 INCH LONG POZI PAN STAINLESS STEEL PLASTITE SCREW	Torque to 2.6 Nm	8
5	917973	FRONT LIFT MAIN ASSEMBLY		1
6	219719	M6 X 16MM LONG HEXAGONAL STAINLESS STEEL HEAD BOLT	Torque to 2.6 Nm	2
7	219642	M6 STAINLESS STEEL NYLON INSERT HALF NUT		2
8	917883	M5 x 6mm T25 Torx Flanged Button Screws SS w/ Threadlock	Torque to 2.6 Nm	2
9	917882	FLANGED BUSH BEARING 6.5 ID 8.5 OD		4
10	219870	M6 FORM A WASHER STAINLESS STEEL		2
11	911783	M5 X 10MM BUTTON HEAD ST 6-LOBE PIN BARREL NUT (T25)	Torque to 2.6 Nm	2
12	917886	SOLENOID ASSEMBLY		1
13	219393	P CLIP		1
14	219560	M6 FORM B STAINLESS STEEL WASHER		2

Numatic International Spare Parts

Model No: FRONT LIFT TOP LEVEL ASSY

NB: FOR WIRING SEE DRAWING: WD-0???

917973
DRAWING: DRW-41934 ISS:A03
13/06/2024

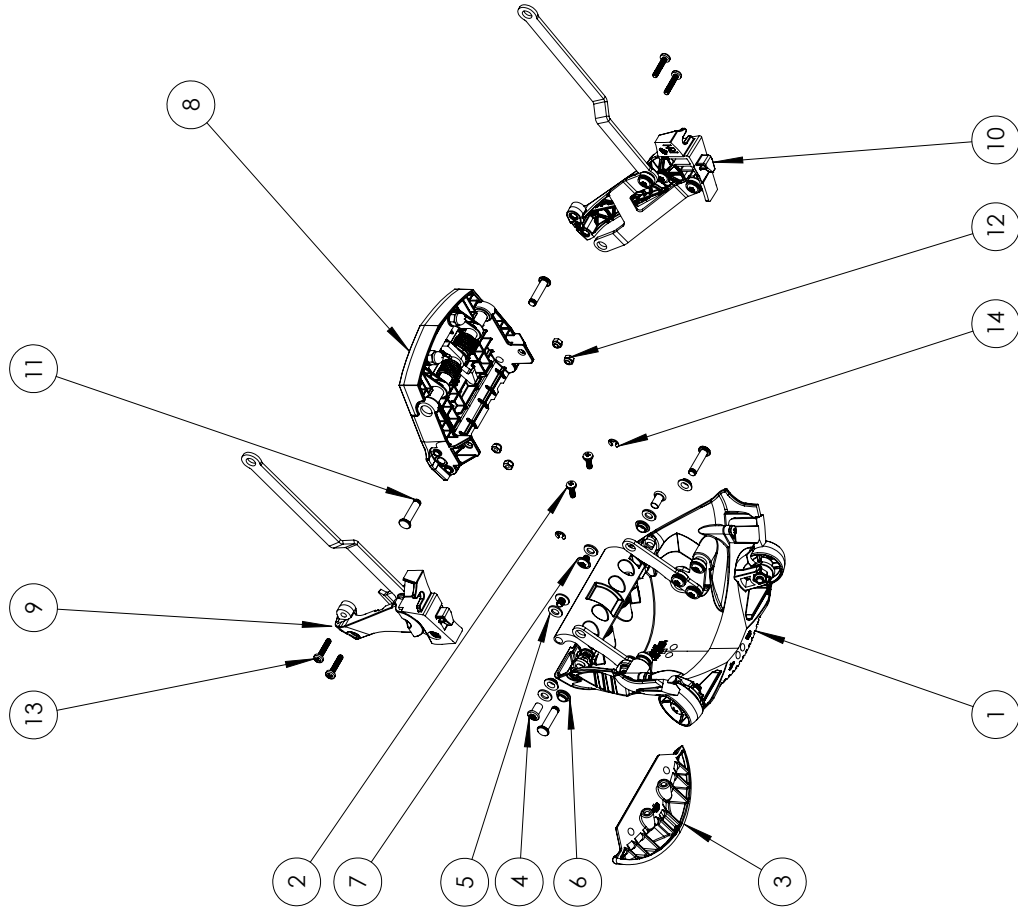

Numatic International Spare Parts

Model No: FRONT LIFT TOP LEVEL ASSY

ITEM NO.	Part No.	DESCRIPTION	COMMENTS	QTY.
1	917972	FRONT LIFT SUB-ASSEMBLY		1
2	219569	No8 X 1/2 INCH LONG POZI PAN STAINLESS STEEL PLASTITE SCREW	Torque to 2.6Nm	2
3	917827	FRONT SUPPORT FOOT GRIP		1
4	911783	M5 X 10MM BUTTON HEAD ST 6-LOBE PIN BARREL NUT (T25)	Torque to 2.6 Nm	2
5	219870	M6 FORM A WASHER STAINLESS STEEL		4
6	917882	FLANGED BUSH BEARING 6.5 ID 8.5 OD		4
7	917883	M5 x 6mm T25 Torx Flanged Butifon Screws SS w/ Threadlock	Torque to 2.6 Nm	2
8	917967	FRONT LIFT SHROUD & RELEASE ASSY		1
9	917966	LH LIFT HINGE ARM ASSEMBLY		1
10	917965	RH LIFT HINGE ARM ASSEMBLY		1
11	912703	6MM X 22MM S/S CLEVIS PIN WITH E-CLIP GROOVE		4
12	219687	M4 STAINLESS STEEL NYLON INSERT NUT		4
13	219686	M4 X 20MM LONG STAINLESS STEEL POZI PAN MACHINE SCREW	Torque to 2.6Nm	4
14	912704	E-CLIP RSM0040 DIN 6799		2

Numatic International Spare Parts
Model No: 325MM SQUEEGEE ASSEMBLY

917902
 DRAWING: DRW-41986 ISS-A06
 22/10/2025

NB: FOR WIRING SEE DRAWING: WD-0777

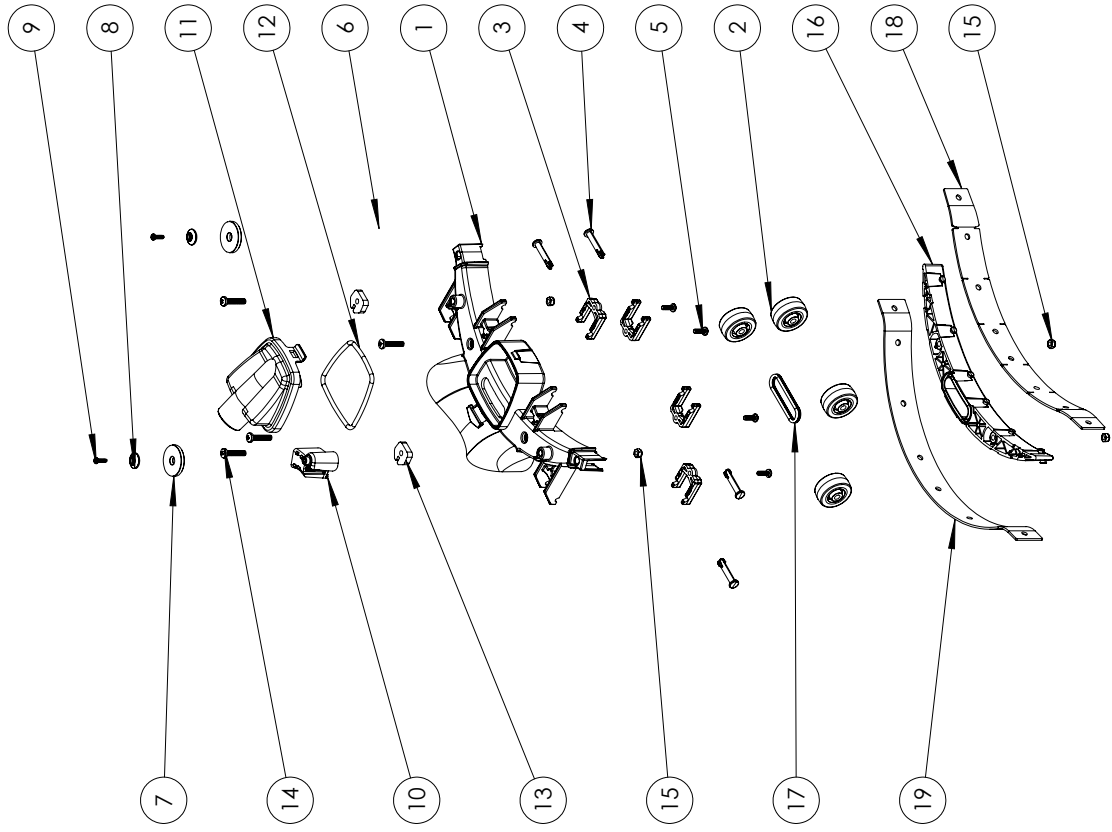

Numatic International Spare Parts
Model No: 325MM SQUEEGEE ASSEMBLY

ITEM:	PART No:	Description	COMMENTS	QTY.
1	917799	325MM SQUEEGEE OUTER		1
2	208454	36MM DIA GREY WHEEL		4
3	917807	SQUEEGEE WHEEL MOUNT ATTACHMENT		4
4	911517	NUC SNAP LOCK PIN (BLACK)		4
5	219569	№8 X 1/2 INCH LONG POZI PAN STAINLESS STEEL PLASTITE SCREW	Torque to 2.6Nm	4
6	917231	LEFT HAND NUC420 FLOOR TOOL CLIP - BLACK		1
7	237266	BUFFER WHEEL		2
8	208603	NYLON FINISHING WASHER (BLACK)		2
9	291053	3.5 X 12MM POZI PAN PLASTITE SCREW SIS	Torque to 1.6Nm	2
10	917232	RIGHT HAND NUC420 FLOOR TOOL CLIP		1
11	917806	SQUEEGEE FLUID TRAP LID		1
12	917889	FLUID TRAP LID GASKET		1
13	917903	325MM SQUEEGEE SNAP PLATE		2
14	219575	M5 X 25MM LONG POZI PAN STAINLESS STEEL SCREW	*Torque to 1.6Nm	4
15	219633	M5 STAINLESS STEEL NYLON INSERT NUT		4
16	917805	325MM SQUEEGEE INNER		1
17	209077	SQUEEGEE SEAL EXTRUSION		1
18	917888	FRONT SQUEEGEE BLADE		1
19	917892	REAR SQUEEGEE BLADE		1