

INSTRUCTION MANUAL

SW3000

559504939 A (02.2025)

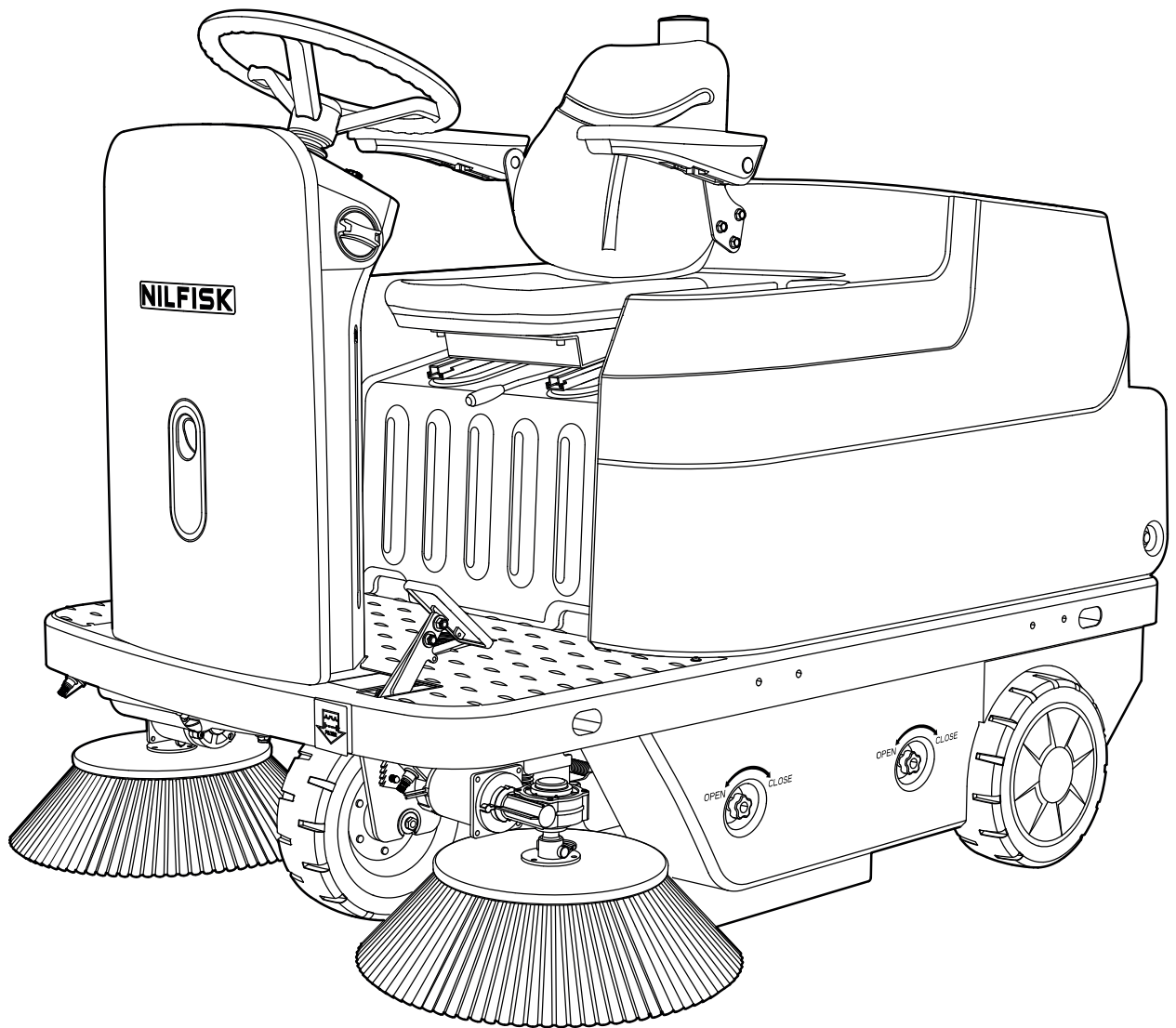

Model No.:
50000741,50000758



NILFISK

TABLE OF CONTENTS

ENGLISH	INSTRUCTION FOR USE.....	1-34
FRANÇAIS	INSTRUCTIONS D'UTILISATION	35-68
ESPAÑOL	INSTRUCCIONES DE USO	69-102

Contents

Introduction	2
Guide Purpose and Contents.....	2
How to Keep the Manual	2
Declaration of Conformity	2
Accessories and Maintenance.....	2
Changes and Improvements	2
Scope of Application.....	3
Machine Identification Data	3
Transport and Unpacking	3
Safety	3
Safety Symbols on the Machine	3
Safety Symbols in the Manual	4
General Safety Instruction.....	4
Machine Description.....	6
Machine Components *-Optional Parts.....	6
Control Panel.....	8
Accessories.....	12
Technical Parameters	13
Circuit Diagram.....	14
User Guide	17
Battery check/setting on a new machine.....	17
Battery type setting.....	18
Before Starting the Machine.....	19
Starting and Stopping the Machine.....	20
Parking Brake	20
Machine Operation	21
Hopper	21
Side Broom Installation	22
Spray Flow Setting.....	22
After Using the Machine.....	23
Towing/Pushing the Machine.....	23
Long-Term Storage	23
First Use	23
Maintenance.....	23
Scheduled Maintenance Table	24
Battery Charging	25
Checking and Adjusting the Main Broom Height	26
Replacing the Main Broom	28
Checking and adjusting the side broom height	29
Cleaning and Replacing the Dust Filter	30
Checking and Replacing the Blade.....	31
Chain Tension Check and Adjustment	32
Troubleshooting	33
Destruction	34

Introduction

Warning!



For general information or additional details not included in this manual, please scan the QR code on the right to view the instructions.



Notes

The numbers in parentheses can be found in the corresponding illustrations.

Guide Purpose and Contents

This manual is intended to provide the necessary information for the correct and safe use of the machine. The information includes the machine's technical data, safety, operation, storage, maintenance, accessories, and disposal instructions.

Before performing any operation or maintenance steps on the machine, both the operator and qualified technicians must read this manual carefully.

For any questions regarding the interpretation of this manual or if more information is needed, please feel free to contact our after-sales service department or distributor.

How to Keep the Manual

This manual must be kept near the machine for easy access. To avoid contamination or damage from liquids or other substances, store the manual in an appropriate bag or box.

Declaration of Conformity

The Declaration of Conformity applies to this machine and ensures that the machine complies with legally mandatory requirements.



Notes

A copy of the original Declaration of Conformity is provided along with machine documentation.

Accessories and Maintenance

All the necessary operations, maintenance, and repair procedures must be carried out by qualified personnel or an authorized service center designated by our company. Only original or approved spare parts and accessories can be used.

For any service or purchase of accessories or spare parts, please contact our company and provide the machine's model and serial number.

Changes and Improvements

Our company is committed to continuous product improvement and reserves the right to make changes and improvements to products already sold without prior notice.

Scope of Application

The machine applies to commercial and industrial use. It is suitable for cleaning smooth and solid floor (sweeping and debris collection). It must be operated by qualified personnel in safe circumstances.

Machine Identification Data

The model and serial number of this machine are marked on the serial number label.

This information is crucial. Use the following table to write down the machine identification data when requiring spare parts for the machine.

Machine Model:
Machine Serial Number:

Transport and Unpacking

When receiving the machine, please check that the packaging and machine are intact. If any damage is found, ensure that the delivery personnel are informed and that the damage is documented in writing before accepting the delivery, retaining the right to claim compensation for any damages.

Follow the instructions on packing strictly when unpacking the machine.

Check the package to ensure following items are included:

1. Technical documentations - Instruction for Use
2. Battery connection cables.
3. Charger manual (if installed) (*).

Safety

The following symbols indicate potential hazards. Please carefully read this information and take necessary precautions to avoid possible personal injury or property damage.

Safety Symbols on the Machine



Warning!

Read all the instructions carefully before performing any operation on the machine.



Warning!

Do not wash the machine with direct or pressurized water jets.

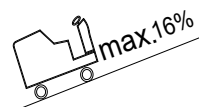

Warning!

Do not use the machine on slopes with gradients exceeding the specified limit.

Safety Symbols in the Manual



Danger!
This indicates a danger that could cause operator death.



Warning!
This indicates a potential danger that could harm personnel or equipment.



Caution!
This indicates a warning about important matters or useful functions. Pay attention to paragraphs with this symbol.



Note
This indicates a suggestion about important matters or useful functions.



Consultation
It indicates the necessity to refer to the Instruction for Use manual before performing any procedure.

General Safety Instruction

Specific warnings and cautions to inform about potential damages to people and machine are shown below.



Danger!

- This machine must be operated by trained and authorized personnel according to guidance of the manual.
- Before performing any usage, maintenance, repair, or parts replacement, ensure you have thoroughly read the manual, the machine is turned off, and the battery is disconnected.
- Do not use this machine near toxic, hazardous, flammable, or explosive dust, liquids, or vapors. This machine is not suitable for cleaning hazardous dust.
- Do not wear jewelry or accessories when working near electrical components.
- Do not work underneath the machine unless it is securely supported.
- When using a wet cell battery, the battery may release flammable gases during normal operation; keep away from open flames, sparks, strong light, or hot objects.
- When using a wet cell battery, the battery may release small amounts of hydrogen gas; ensure the charging environment is well-ventilated and far from open flames.



Warning!

- This machine is intended for commercial use, such as in hotels, schools, hospitals, factories, stores, offices, and rental businesses.
- When the machine is not in use, it should be secured to prevent accidental movement.
- To prevent unauthorized use, the machine's power should be turned off or locked, such as by removing the key switch.
- Before each use, carefully inspect the machine to ensure all parts are correctly installed; otherwise, it may pose a risk to people or property.
- Before charging the battery with the charger, ensure the power frequency and voltage match those indicated on the machine's serial number label.
- Do not pull the charger cord to move the machine. Do not allow the cord to pass through a closed door, and do not wrap it around objects with sharp edges or corners. Do not let the machine roll over the power cord. Keep the charger cord away from hot surfaces.
- If the charger cord or plug is damaged, do not charge the machine.
- To avoid fire, electric shock, or personal injury, ensure the machine is turned off when not in use.

- This machine is not suitable for outdoor use and is only intended for indoor use. Store it in a dry indoor environment when not in use.
- The storage and operating temperature of the machine must be between 0°C and +40°C, with environmental humidity maintained between 30% and 95%.
- Do not use the machine on slopes exceeding the specified gradient.
- When using floor cleaning liquids, follow the instructions on the cleaning solution bottle and wear appropriate gloves and other protective gear.
- Use only the side brooms, main brooms, and components specified in the user manual that come with the machine. Using other side brooms or main brooms may reduce safety.
- If the machine malfunctions, ensure that it is not due to a lack of maintenance. In case of other issues, seek assistance from authorized personnel or a service center.
- Take all necessary precautions to avoid the risk of hair, jewelry, and loose clothing being caught in the machine's moving parts.
- Do not use the machine in areas with excessive dust accumulation.
- Do not wash the machine directly with water or high-pressure water guns, and avoid using corrosive substances for cleaning.
- Avoid collisions with surrounding objects while using the machine, especially if the collision could cause falling objects.
- When the machine is stationary, stop using the side brooms and main brooms to prevent floor damage.
- In the event of a fire, use a dry powder extinguisher. Do not use liquid extinguishers.
- Do not remove or alter the labels on the machine.
- Do not attempt to modify the machine's safety protections. Always follow the maintenance guidelines.
- Pay special attention when transporting the machine in temperatures below 0°C. If there is water in the tank or pipes, it may freeze and cause severe damage.
- If parts need to be replaced, obtain original parts from authorized dealers or agents.
- If the machine is damaged, placed outdoors, or submerged in water and is not functioning properly, send the machine to a service center.
- To ensure safe and correct operation, have authorized personnel or a service center perform regular maintenance according to the maintenance schedule in the relevant sections of the manual.
- The machine must be properly disposed of, as it contains toxic and harmful materials (such as batteries), which must be disposed of at specific centers in accordance with relevant regulations (see the disposal section).
- This machine is intended solely as a cleaning tool and should not be used for any other purpose.
- Keep the work area clear. Do not use the machine in areas where pathways are blocked. Ensure that the airways are not blocked by dust, hair, or any other objects that may obstruct airflow.
- Use the machine in well-lit areas.
- The machine should only be operated by properly trained or authorized personnel. Children or unauthorized individuals should not operate the machine.
- Extra caution must be taken when using the machine near children.
- Ensure that children do not play with the machine to avoid accidents.
- When using the machine, avoid causing harm to people or objects.
- Children should not clean or maintain the machine without adult supervision.
- Operators should be adequately instructed on how to use the machine.
- Do not use the machine in environments where there is a high risk of falling objects hitting the operator and the machine is not equipped with a canopy (FOPS).
- The headlights are only for improving the visibility of the surface being cleaned and should not be used in dark environments.
- Prevent the machine from being exposed to direct sunlight, rain, or harsh weather conditions, whether it is operating or not. Store the machine in a dry indoor environment: the machine must be used in a dry environment and should not be used or stored in damp outdoor conditions.
- Adjust the operating speed based on the ground conditions.
- When the machine is going downhill, drive at low speed to avoid sudden stops. Avoid sharp turns.
- This machine should not be used on roads or public streets.
- The recommended maximum weight of the operator for this equipment is 120kg (265lbs), as recommended for optimal safety and machine performance. Operating the equipment outside of this range may compromise safety and durability. Ensuring safer operation, the operator of the machine must fit within the confines of the equipment. Please consult your supervisor or equipment manufacturer for specific concerns.

Machine Description

Machine Components *--Optional Parts

- 1. Turn indicator
- 2. Air outlet bracket
- 3. Filter compartment cover
- 4. Knurled knob
- 5. Hopper
- 6. Latch
- 7. Steering wheel
- 8. Control panel
- 9. Emergency stop switch
- 10. USB port
- 11. Main broom adjustment knob
- 12. Phone bag
- 13. Accelerator pedal
- 14. Auxiliary hole of the machine
- 15. Chassis
- 16. Right cover
- 17. Blade
- 18. Rear wheels
- 19. Internal/external charging port
- 20. Warning light
- 21. Seat (with seat switch)
- 22. Blue light (*)
- 23. Logo label
- 24. Head lamp
- 25. Operating indicator
- 26. Spray nozzle
- 27. Right bumper
- 28. Side broom
- 29. Front wheel
- 30. Cover
- 31. Left bumper
- 32. Water level indicator
- 33. Parking brake
- 34. Flap pedal
- 35. Left side panel
- 36. Cup holder
- 37. Cover

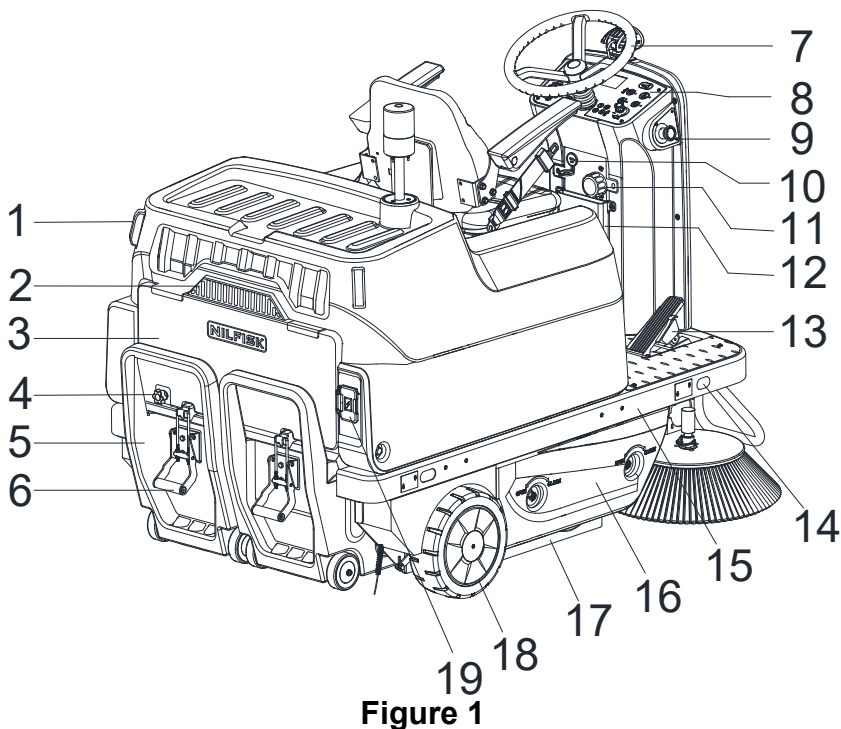

Figure 1

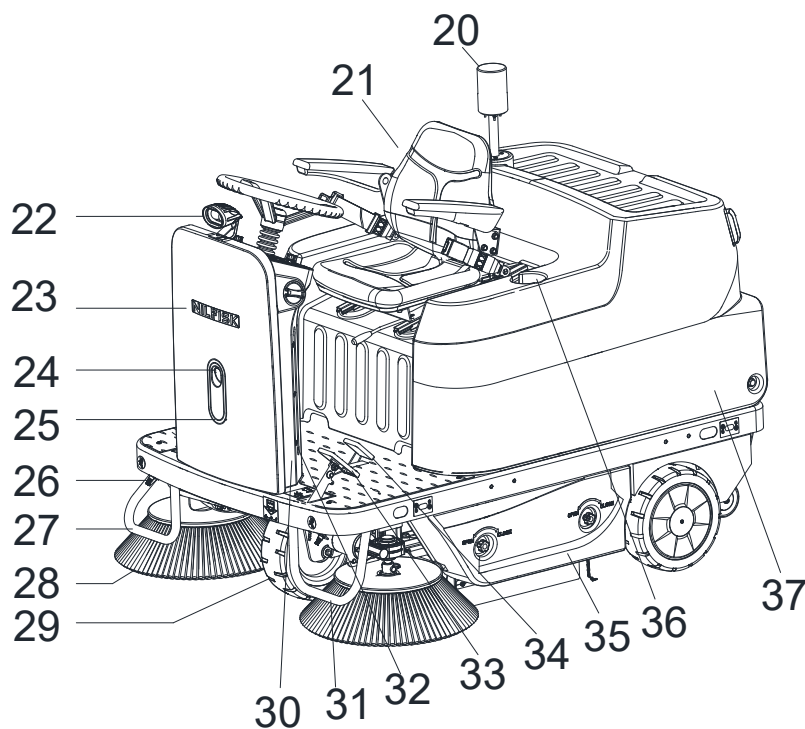

Figure 2

- 38. Hood support cable
- 39. Circuit breaker box
- 40. Battery connector
- 41. Battery (*)
- 42. On-board charger (*)
- 43. Auto brake
- 44. Battery tray
- 45. Main broom

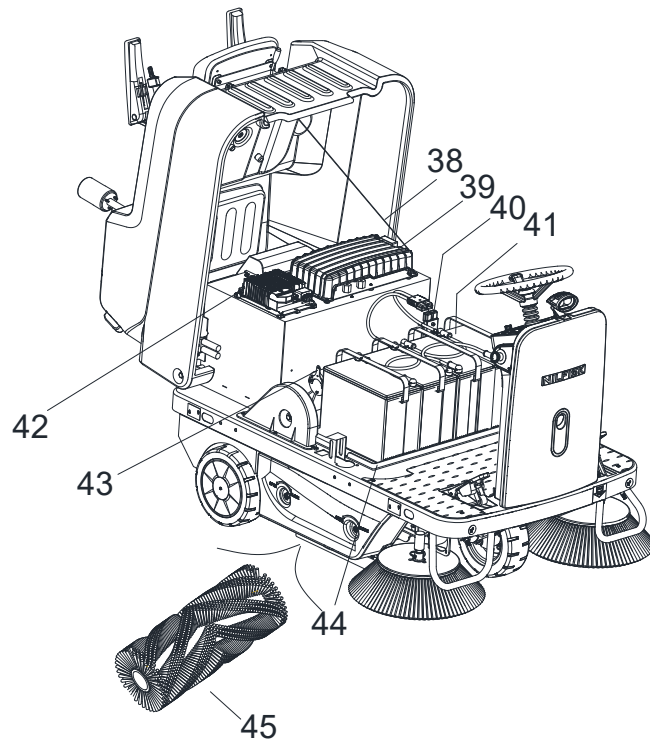

Figure 3

Control Panel

46. Multifunctional display

Items displayed:

- A) Login screen
- B) Home screen
- C) Menu screen
- D) Safety stop mode
- E) Reverse mode
- F) Brake mode
- G) Operating time
- H) Battery level
- I) On the login screen, use the indicator left button(56) to delete the incorrect password
- J) On the login screen, use the start button(47) to confirm the password
- K) Dust fan status
- L) Filter shaker status
- M) Side broom status
- N) Press the start button(47) to enable cleaning mode.
- O) Dust guard spray status
- P) On the menu screen, short press ① to return to the previous page
- Q) On the menu screen, short press the indicator left button(56) to scroll down the item.
- R) On the menu screen, short press the indicator right button(57) to scroll up the item
- S) On the menu screen, short press ② to confirm the option

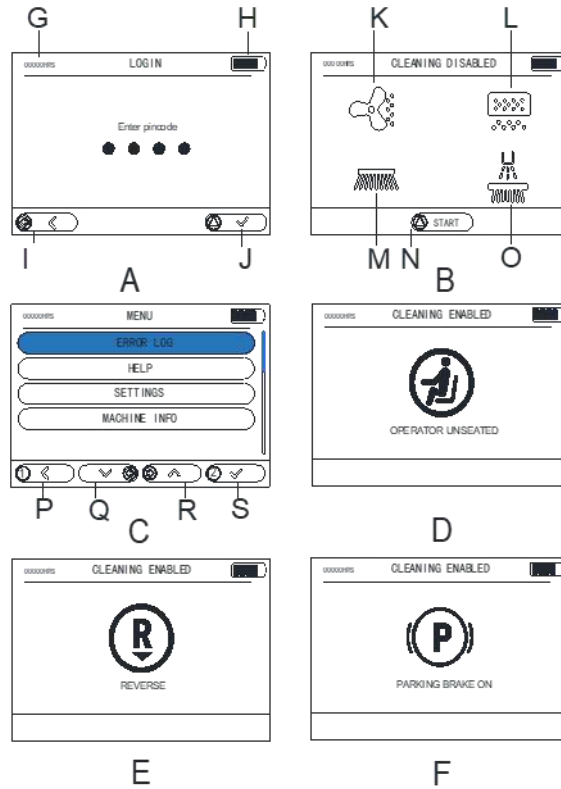

47. Start button

Turn on/off cleaning mode, turning on cleaning mode will automatically activate the main broom, side brooms, and dust fan.

48. Dust fan button

49. Filter shaker button

- Enable/Disable dustproof function
- Press for 2 seconds to activate automatic mode (Filter shaker LED flashes), press for 2 seconds again to exit the automatic mode.

50. Side broom button

51. Dust guard spray button

52. Side broom speed dial

53. Power button

54. 4-digit pin pad

55. Machine speed dial

56. Indicator left button

57. Indicator right button

58. Reverse button

59. Headlight button

60. Horn button

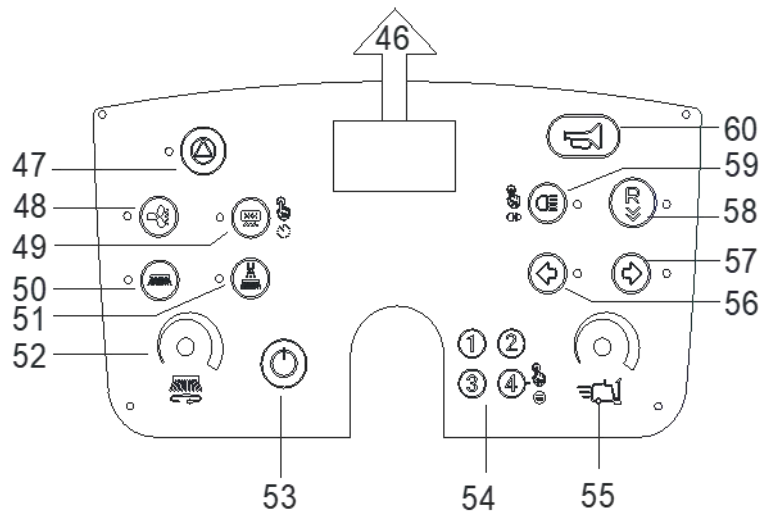
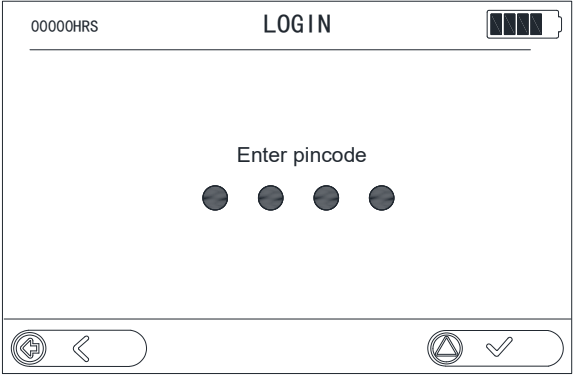
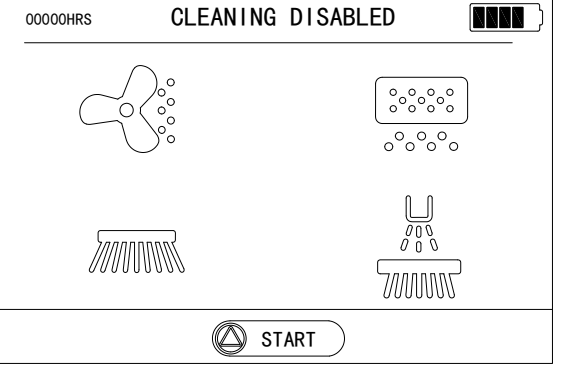
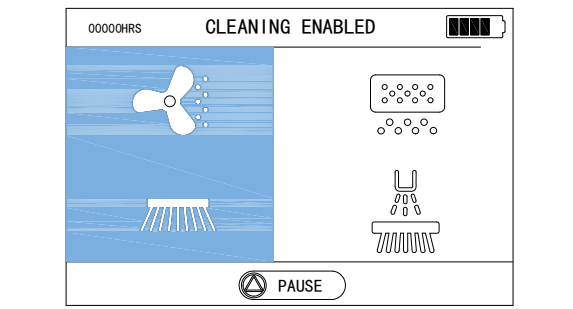
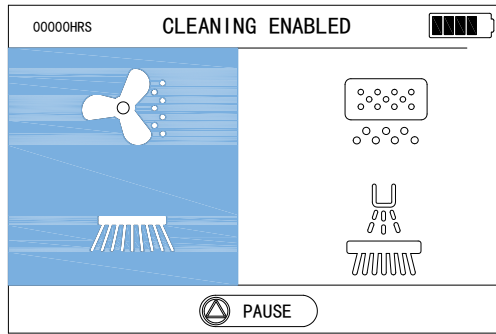

Figure 4

Working Mode Description

Operation Mode	Screen Display	State Description
<p>Login Interface</p> <ul style="list-style-type: none"> - Press the power button (53) to enter the startup interface, which will then automatically switch to the login interface. - Use the 4-digit pin pad (54) to enter a 4-digit password. The default password is 1234, and users can change the password in Settings. 		<ol style="list-style-type: none"> 1. The top-left corner of the LCD screen displays the machine's operating time. 2. The top-right corner of the LCD screen displays the battery level. 3. The main title on the LCD screen is LOGIN. 4. As user inputs the password, the interface changes according to the entered digits. 5. If the password is entered incorrectly, user can use the indicator left button (56) to delete the incorrect password. 6. After entering the 4-digit password, press the start button (47) to confirm and log in with the entered password. If the password is correct, the Home interface will appear. If incorrect, the password error interface will appear, and after 2 seconds, it will return to the password input interface. 7. If the password is entered incorrectly five times in a row, the machine will lock for 5 minutes. After 5 minutes, the login interface will appear again.
<p>Home Interface</p> <ul style="list-style-type: none"> - Press the power button (53). - Login successful. 		<ol style="list-style-type: none"> 1. The operating time does not start timing. 2. The main title on the LCD screen is CLEANING DISABLED. 3. Cleaning is disabled. The main broom, side broom, dust fan, and dust guard spray functions are disabled, and the icons for the side broom, dust fan, and dust guard spray are dimmed. 4. The filter shaker icon is highlighted, and the filter shaker function is enabled. 5. Short press the filter shaker button(49), the filter shaker LED indicator is steady on, and the background of the filter shaker icon is highlighted. After one working cycle, the filter shaker automatically stops, the LED turns off, and the background of the filter shaker icon returns to low brightness. 6. Press the filter shaker button for 2 seconds, it will enter the automatic mod, the filter shaker LED indicator flashes.
<p>Cleaning mode</p> <ul style="list-style-type: none"> - Press the power button (53). - Login successful. - Press the start button (47). 		<ol style="list-style-type: none"> 1. The operating time does not start timing. 2. The main title on the LCD screen is CLEANING ENABLED. 3. The main broom, side broom, and dust fan are automatically activated. The main broom and side broom drop to the ground, the backgrounds of dust fan and side broom icons are highlighted, and the LED indicators are steady on. 4. Filter shaker and dust guard spray functions are turned off by default, but the filter shaker and dust guard spray icons are highlighted, allowing the user to manually turn them on.

- Press the power button (53).
- Successful login.
- Press the start button (47).
- Seat safety switch (21) turned on (sit on the seat).
- Press the accelerator pedal (54).



1. The operating time start timing.
2. The main title on the LCD screen is CLEANING ENABLED.
3. The main broom, side broom, and dust fan start working.
4. If the dust guard spray is turned on and there is water in the water tank, the dust guard spray starts work.
5. If the filter shaker function is enabled, the filter shaker motor will operate. When the filter shaker motor is working, the fan will automatically stop. Once the filter shaker motor stops, the fan will automatically resume working.

Menu Interface

- Press the power button (53).
- Successful login.
- Press the button ④ of 4-digit pin pad (54) for 2 seconds

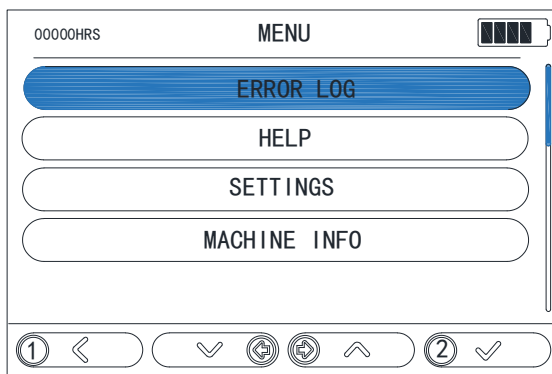

1. The operating time does not start timing.
2. The main title on the LCD screen is MENU.
3. The MENU includes ERROR LOG, HELP, SETTINGS, and MACHINE INFO.
4. Use the button ① of 4-digit pin pad (54) to return to the previous screen, use the indicator left button (56) to scroll down, use the indicator right button (57) to scroll up, and use button ② to confirm a selection.
5. ERROR LOG allows user to view the list of error messages.
6. HELP provides service information.
7. MACHINE INFO allows user to view product information.

Reverse Mode

- Press the power button (53).
- Successful login.
- Seat safety switch (21) turned on (sit on the seat).
- Press the reverse button (58).

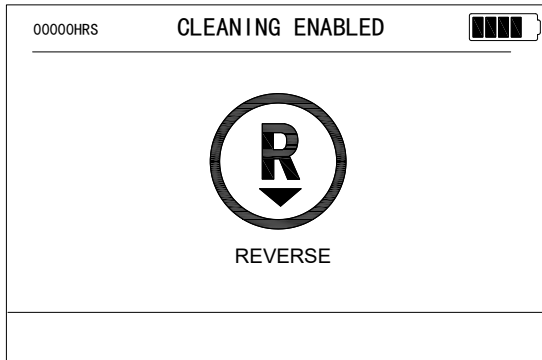

The horn sounds a "beep beep..." to indicate a reverse warning.

Brake/Park Mode

- Press the power button (53).
- Successful login.
- Seat safety switch (21) turned on (sit on the seat).
- Press the brake (33).

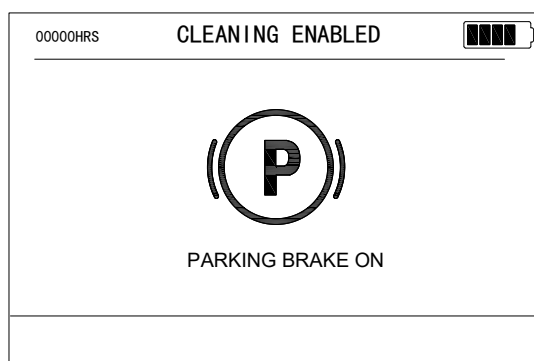

The machine stops moving, and other functions remain in their current state.

Operation Mode	Screen Display	State Description
Safe Stop Mode		

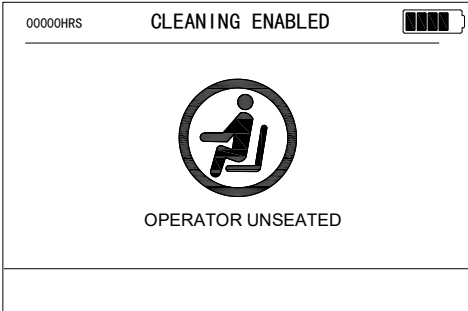
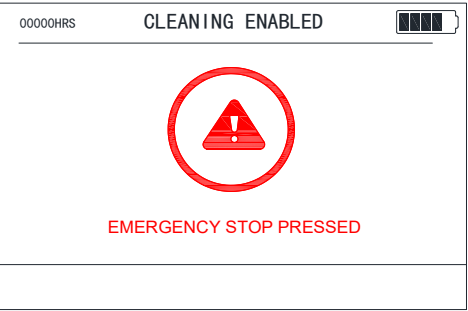
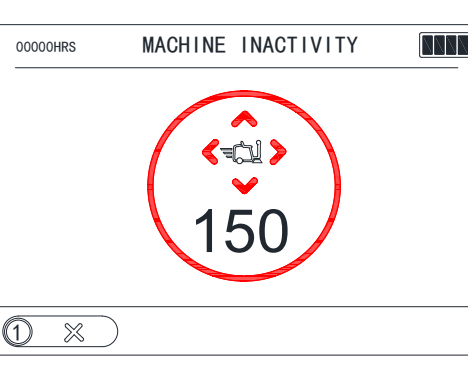
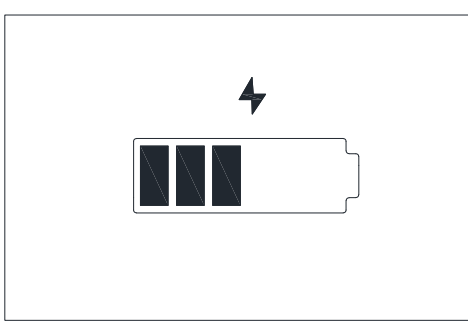
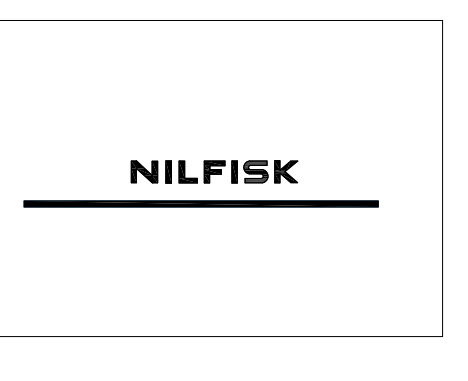
<ul style="list-style-type: none"> - Press the power button (53). - Successful login. - The seat safety switch (21) is turned off (operator leaves the seat). 		<p>All functions will be turned off except for the horn and lights.</p>
<p>Emergency Stop Mode</p>		
<ul style="list-style-type: none"> - Press the power button (53). - Press the emergency stop switch (9). 		<p>All functions are turned off. After releasing the emergency stop button, the machine needs to be restarted by pressing the Power button to restore normal operation.</p>
<p>Automatic Shutdown Interface</p>		
<ul style="list-style-type: none"> - Press the power button (53). - Successful login. - The seat safety switch (21) is turned off (operator leaves the seat). - 5 minutes of inactivity (the inactivity time can be modified in the parameter settings). 		<ol style="list-style-type: none"> 1. If the INACTIVITY TIME value is set to 0, the shutdown countdown is disabled. 2. If the INACTIVITY TIME value is not 0, the shutdown countdown interface will display after the machine is idle for (INACTIVITY TIME) / 2. When the countdown ends, the machine will automatically shut down. 3. Press button ① or press the accelerator pedal to cancel the shutdown countdown.
<p>Charging Mode</p>		
<ul style="list-style-type: none"> - Connect the built-in charging plug to the power grid. 		<ol style="list-style-type: none"> 1. The LCD screen will display the charging status of the battery. 2. All functions will automatically shut down.
<p>Shutdown mode</p>		
<ul style="list-style-type: none"> - Press the power button (53). 		<ol style="list-style-type: none"> 1. Enter the power cut-off state. 2. The LCD screen will turn off.

Accessories

The following accessories are optional:

1. Wet/Gel/AGM/TPPL battery
2. Battery charger
3. Main broom, side brooms, or hard/soft broom bristles
4. Blue light
5. FOB
6. TC-1

For further information about optional accessories, please contact an authorized retailer.

Technical Parameters

Technical Parameters	Value
Machine length	1620 mm/63.8 Inches
Machine width (without side brooms)	1055 mm/41.5 Inches
Machine height	1260 mm/49.6 Inches
Machine height with overhead guard	1986mm/78.2 Inches
Working width (without side brooms)	700 mm/27.6 Inches
Working width (with two side brooms)	1350 mm /53.1 Inches
Minimum ground clearance (excluding blades)	60 mm/2.4 Inches
Main broom size (diameter x length)	300x700 mm/11.8x27.6 Inches
Side broom size (mm/Inches)	500 mm/19.7 Inches
Main broom speed (rpm)	600 rpm
Side broom speed (rpm)	0~98rpm
Front wheel ground pressure per unit area (N/mm ²)	0.88 N/mm ²
Rear wheel ground pressure per unit area (N/mm ²)	0.6 N/mm ²
Machine weight (without battery) (kg)	361 kg
Machine gross weight (GVW) (kg) without operator	563 kg
Hopper volume (l)	100L
Main broom motor	Input 624W Output 500W
Side broom motor	Input 280W Output 100W x 2
Drive motor	Input 936W Output 650W
Suction Motor	Input 168W
Water pump	Input 30W
Actuator	Input 60W x 2
Filter shaker motor	Input 144W
Others	Input 58W
Rated power	2640W
Power consumption	948W/1.3HP(Lead-acid) 823W/1.1HP(Li-ION)
Noise level (ISO 11201, ISO 4871) (LpA)	72±3 dB(A)
Sound power (ISO 3744, ISO 4871) (LwA)	86 dB(A)
Vibration level at the operator's arms (ISO 5349-1) (*)	<2.5m/s ²
Vibration level at the operator's body (ISO 2631-1) (*)	<0.5 m/s ²
Motor protection rating	IP24
(*) Performance parameters under normal working conditions on a flat asphalt surface	
Performance	Value
Maximum driving speed	8 km/h
Maximum reverse speed	4 km/h
Gradeability	16% (L=140 meters)
Minimum turning radius width	2550 mm
Battery	Value
Battery voltage	24 V
Battery compartment dimensions (length x width x height)	770 x 340 x 300 (mm)
Dust collection and filtration	
Dust filter size	3.5 m ²
Main broom compartment vacuum	8.8 mm H ₂ O
Filter shaker	Electric

Circuit Diagram WIRING DIAGRAM(Li-ion)

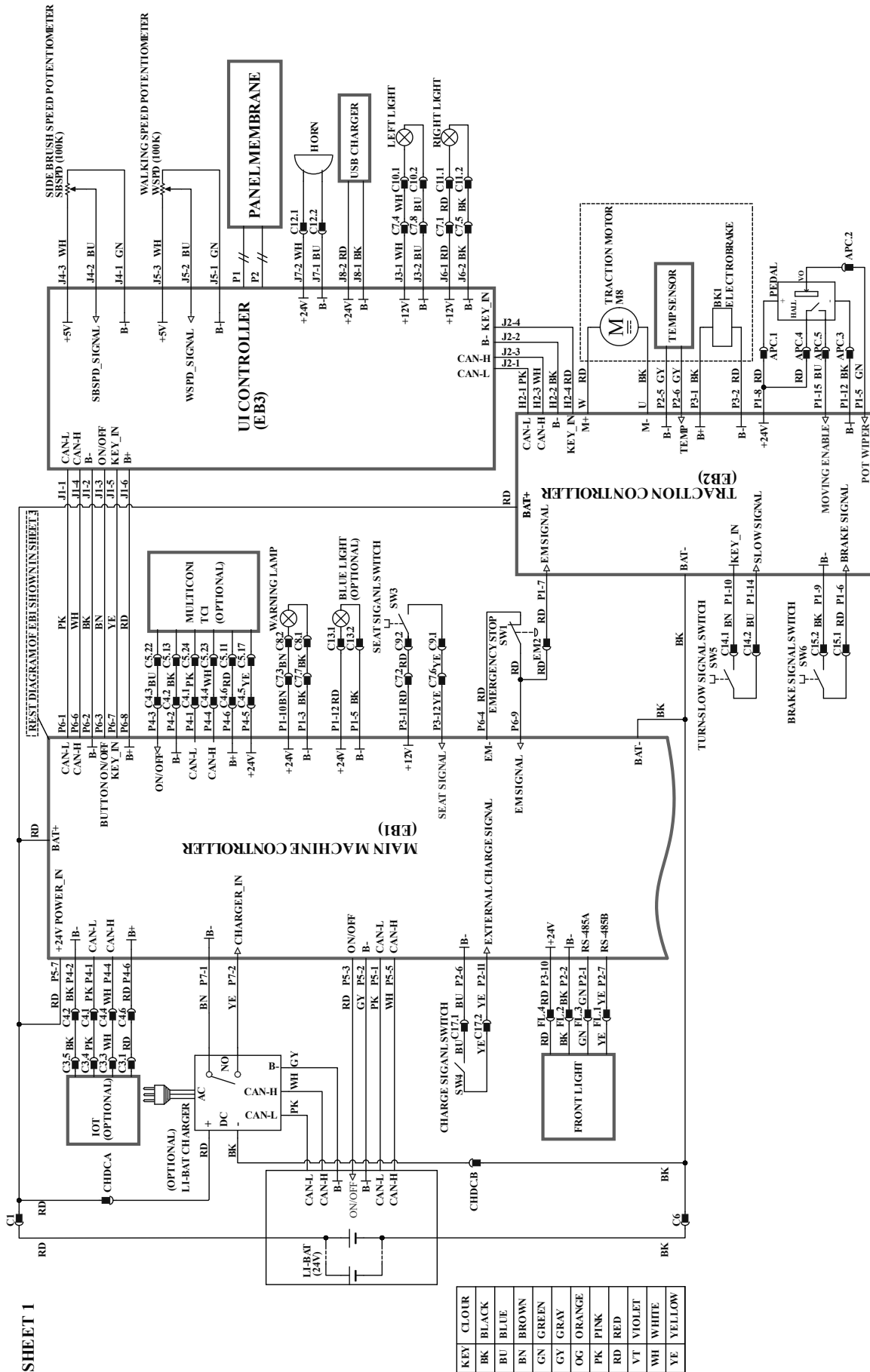

SHEET 1

WIRING DIAGRAM(Lead-acid)

SHEET 2

REST DIAGRAM OF EBI SHOWN IN SHEET 3

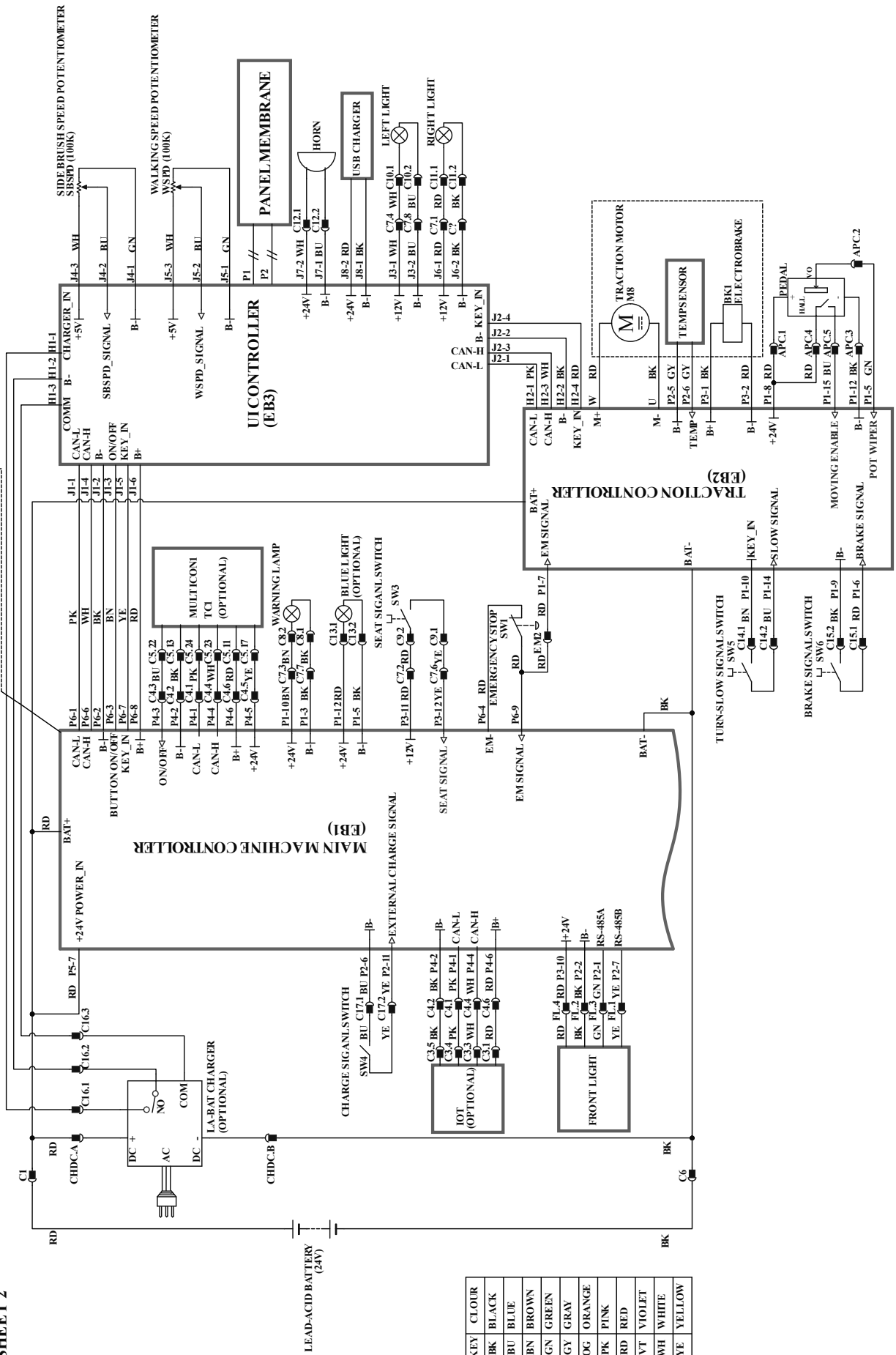

KEY	CLOUR
BK	BLACK
BU	BLUE
BN	BROWN
GN	GREEN
GY	GRAY
OG	ORANGE
PK	PINK
RD	RED
VT	VIOLET
WH	WHITE
YE	YELLOW

COMMON DIAGRAM

SHEET 3

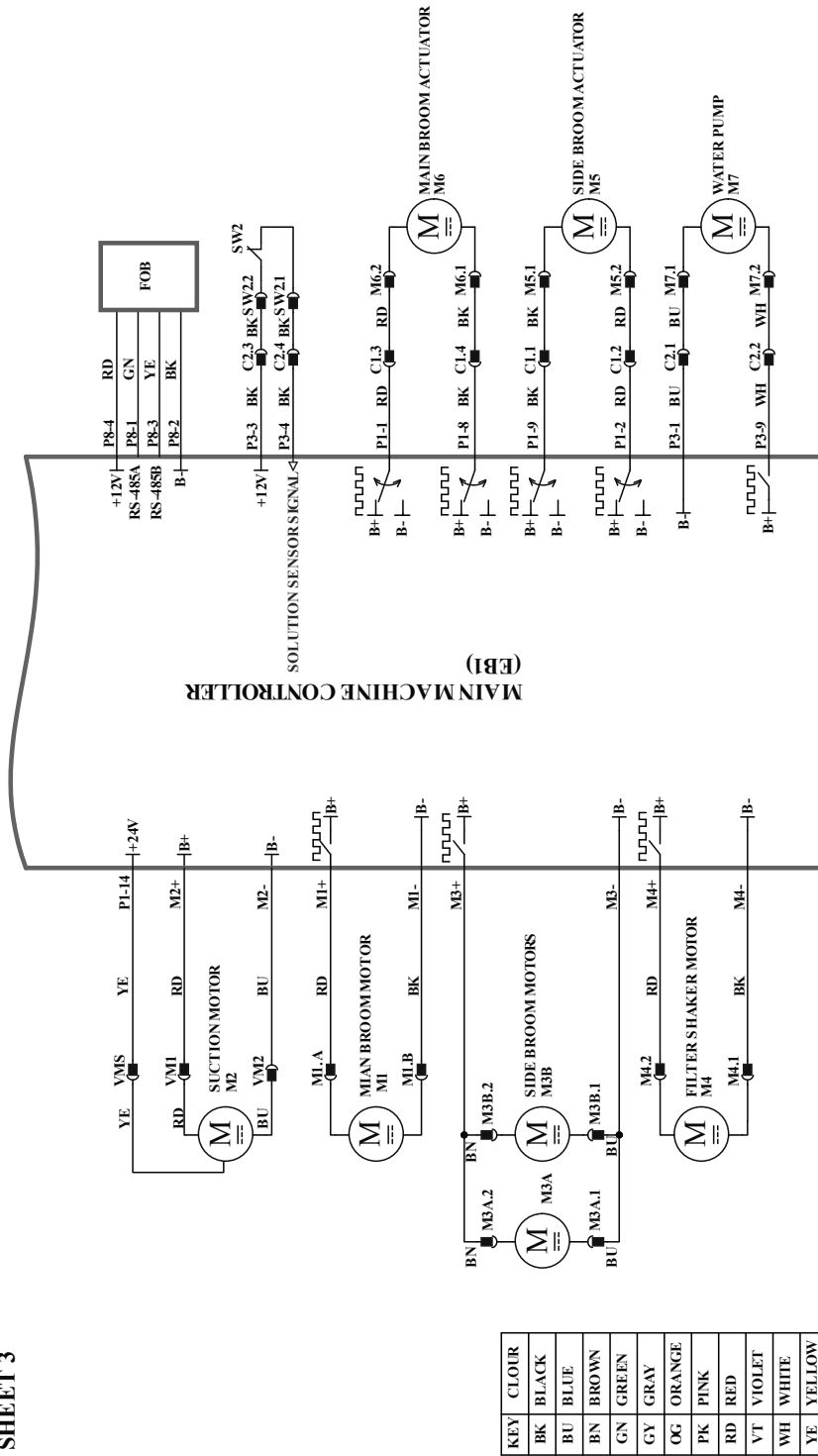

KEY	CLOUR
BK	BLACK
BU	BLUE
BN	BROWN
GN	GREEN
GY	GRAY
OG	ORANGE
PK	PINK
RD	RED
VT	VIOLET
WH	WHITE
YE	YELLOW

User Guide



- Warning!**
There are warning labels on certain parts of the machine:
- Danger!
 - Warning!
 - Caution!
 - Recommendation

Operators must pay special attention to these symbols on the labels when reading this manual. Under no circumstances should these labels be covered. If they are damaged, replace them immediately.

Battery check/setting on a new machine



WARNING!
The electric components of the machine can be seriously damaged if the batteries are either improperly installed or connected. The batteries must be installed by qualified personnel only. Set battery type using the procedures below according to the type of batteries used (WET or GEL/AGM/DIS/EXI/FUL/OPT/ENE(TPPL)). Check the batteries for damage before installation. Disconnect battery connector and battery charger plug. Handle the batteries with great care. Install the battery terminal protection caps supplied with the machine.



NOTE
The machine requires four 6V batteries, connected and installed in the positions shown in Figure 5.

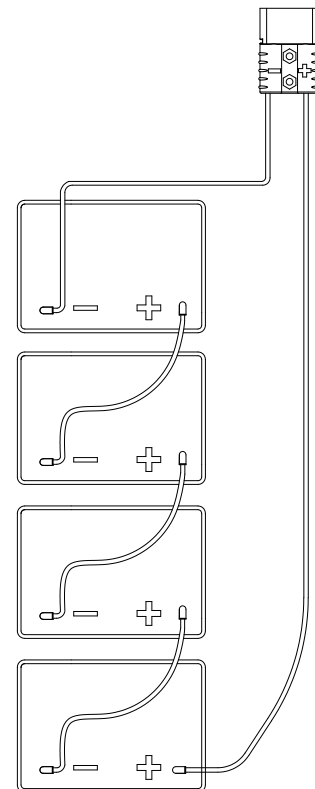

Figure 5

Batteries already installed on the machine

1. Ensure that the battery connector is connected.
2. When first using the machine with new batteries, perform a full charging cycle (see the procedures in Maintenance chapter).

Without batteries

1. Buy appropriate batteries (see “Technical Data” chapter). For battery choice and installation, contact qualified battery retailers.
2. Set battery type according to the procedures below.

Battery type setting

The machine battery type setting is as follows:

1. Press the power button (A, Figure 6).
2. Use the 4-digit pin pad (C, Figure 6) to enter the password. The default password is 1234.
3. After successfully logging in, press and hold ④ button (D, Figure 6) for 2 seconds to enter the MENU interface (K, Figure 6).
4. In the MENU interface, press ① button (B, Figure 6) to go back to the previous menu, press indicator left button (G, Figure 6) to scroll down, press indicator right button (F, Figure 6) to scroll up, select "SETTINGS", then press ② button (E, Figure 6) to confirm the selection and enter the SETTINGS interface (J, Figure 6).
5. In the SETTINGS interface (J, Figure 6), select (I, Figure 6) BATTERY TYPE to enter the BATTERY TYPE settings interface (H, Figure 6).
6. Press indicator left button (G, Figure 6) to scroll down, press indicator right (F, Figure 6) to scroll up, choose the battery type according to the batteries are installed, then press ② button (E, Figure 6) to update the change.
7. The battery selection will set the charging profile if using the onboard charger.
8. Attention, using an external charger, both the machine and the charger must be set according to batteries installed.

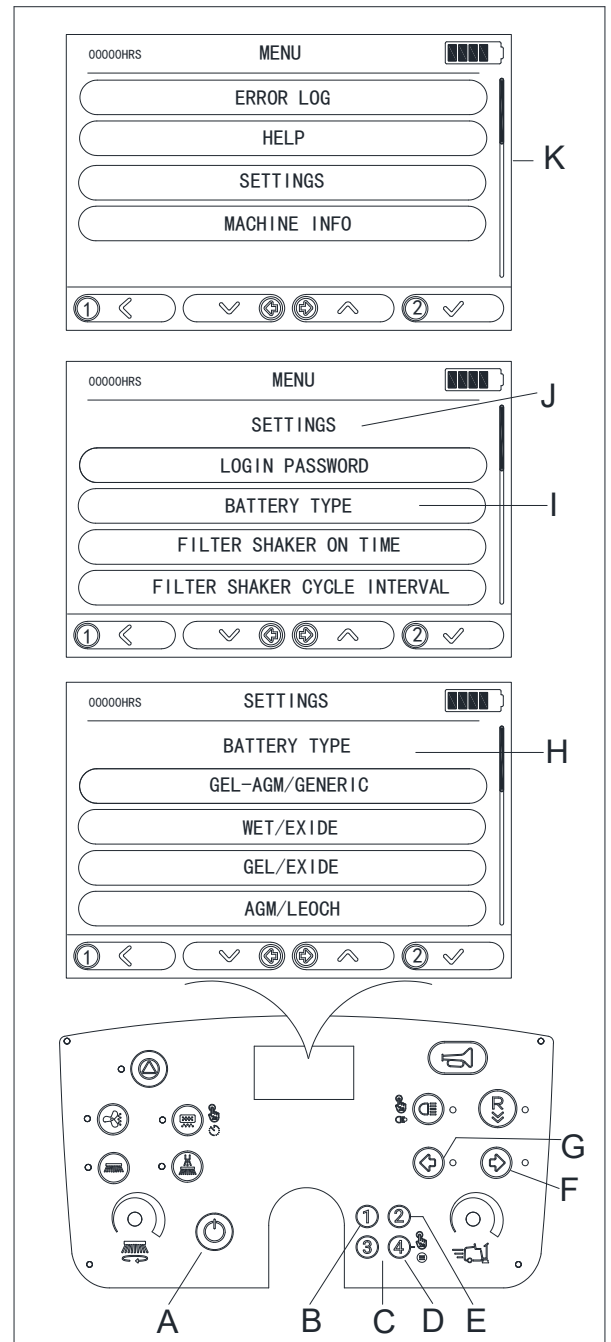

Figure6

Before Starting the Machine

Checklist

9. Fully understand all the control functions of the machine.
10. Sit on the seat (A, Figure 7), and press the power button (G, Figure 7) to start the machine (see the following operating procedure section).
11. Check the battery charge. If the LCD (H, Figure 7) shows the battery icon with 5 bars, it means the battery is fully charged and the machine can be used. If the LCD (H, Figure 7) shows the battery icon with 1 bar or less, the battery needs to be charged. (Refer to the maintenance section for battery charging.)
12. Check the brake (B, Figure 7). The brake must be locked and easy to release (if there are issues, consult the service center).
13. Check the front panel pedal (D, Figure 7) for smooth operation.
14. Press the accelerator pedal (E, Figure 7) to check if the machine can move forward or stop.
15. To ensure the machine's safety, pressing the emergency stop switch (C, Figure 7) will immediately stop the machine. Rotate the emergency stop switch to reset it. If you want to continue using the machine, you need to restart it to exit the emergency stop mode.



Warning!

If the brake pedal feels weak or ineffective when pressed, and the machine cannot be stopped (contact the service center immediately).

16. Ensure the cover and hopper are both closed before operating the machine.
17. Ensure the latch of the hopper (F, Figure 7) is securely fastened.

Cleaning Plan

1. Schedule long operation times, as well as start and stop times.
2. Allow slight overlap of cleaning paths to ensure complete coverage.
3. Avoid sharp turns, collisions, or scraping the machine's sides.

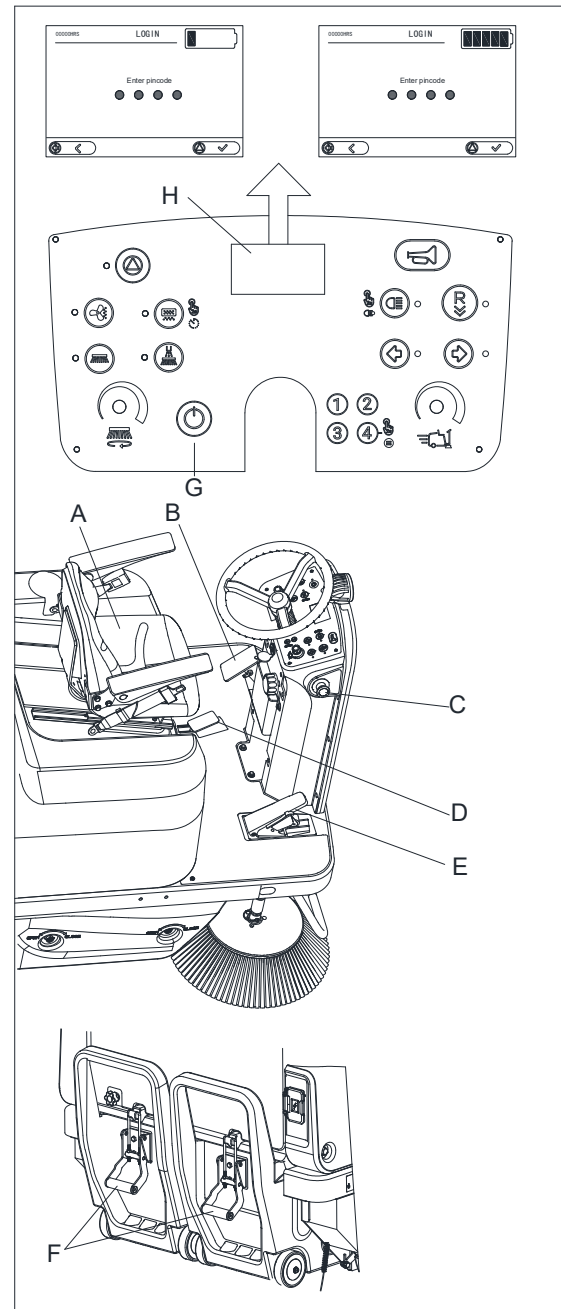

Figure 7

Starting and Stopping the Machine

Starting the machine

1. Sit on the driver's seat (A, Figure 8) and adjust its position with the lever (C, Figure 8) to allow easy reach of all controls.
2. Press the power button (M, Figure 8). Check the battery level on the display. If needed, charge the battery (refer to the maintenance section).
3. Use the 4-digit pin pad (L, Figure 8) to enter the password. The default password is 1234.
4. After successfully logging in, release the brake (E, Figure 8), press the accelerator pedal (G, Figure 8) and drive the machine to the work area.
5. Press the start button (H, Figure 8) to start the cleaning mode. The side brooms and main broom will automatically lower to the ground, and the dust fan will start working.
6. Press the accelerator pedal (G, Figure 8), and steer the machine by holding the steering wheel (C, Figure 8) while pressing the reverse button (J, Figure 8) to drive the machine forward or backward. Adjust the driving speed using the machine speed dial (K, Figure 8).
7. Adjust the side broom speed using the side broom speed dial (N, Figure 8) according to cleaning requirements.
8. When the machine is on, you can charge devices such as a phone or pad via the USB charging port (D, Figure 8).
9. Press the horn button (I, Figure 8) to warn people when necessary.



Note

The suction system of the machine will only operate when the main broom is lowered. The main broom and side brooms (P and O, Figure 8) can be lifted or lowered even while the machine is running. The main broom and side brooms do not rotate when they are lifted.

10. Start sweeping by turning the steering wheel (C, Figure 8) and driving the machine forward with the accelerator pedal ((G, Figure 8).

Stopping the machine

11. Release the accelerator pedal (G, Figure 8) to stop the movement.
12. Press the start button (H, Figure 8) to turn off the main broom, side broom and dust fan. The main broom and side brooms are lifted from the floor automatically. The dust fan system is turned off after a delay of several seconds.
13. Engage the parking brake.

Parking Brake

1. Engage the parking brake by pressing on the front part of the pedal (A, Figure 9) and engaging the lever (B, Figure 9).
2. Press the rear part of the pedal (C, Figure 9) to release the parking brake.



Warning!

Before performing any maintenance, repair, cleaning, or replacement procedures, engage the parking brake. When parking the machine on a slope, engage the parking brake.



Warning!

When the machine is unattended, ensure that the brake can safely stop the machine with a higher safety factor.

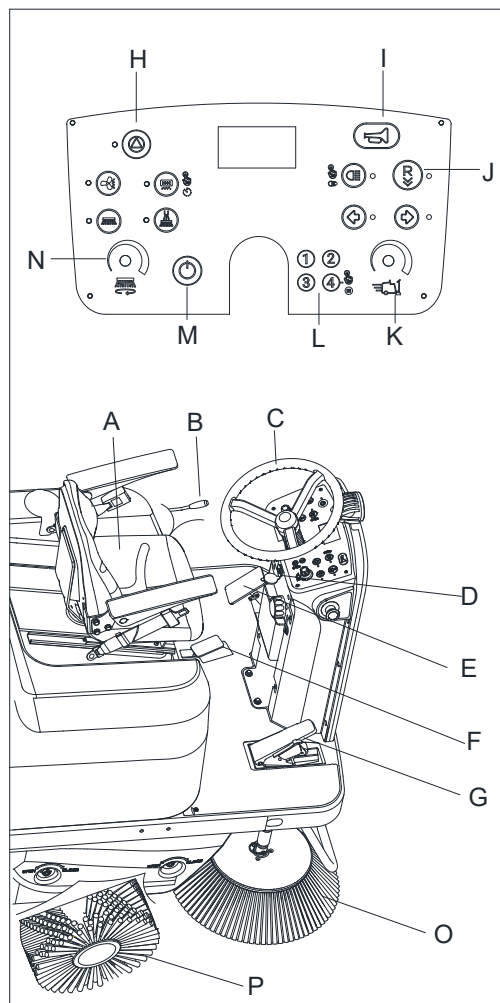

Figure 8

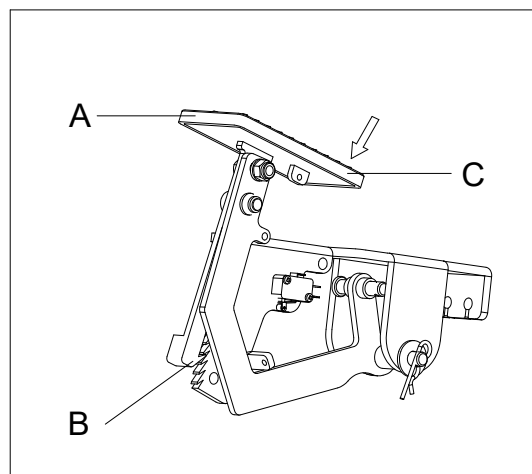

Figure 9

Machine Operation



Warning!

When using the machine on a slope, follow the maximum slope value marked on the machine (refer to the "Technical Data" section).



Warning!

Pay careful attention when operating the machine at high speed: sudden steering could cause this three-wheel machine to become unstable due to weight distribution. Always reduce the speed before steering.

1. Drive the machine to the work area as shown in the previous paragraph.
2. Drive the machine straight forward at high speed. Drive the machine slower when sweeping a large amount of dust or debris or when safe operation requires slower speed. To achieve optimal results, overlapping sweeping paths by over 10 cm is recommended.
3. Avoid stopping the machine in the same position for a long time with the brooms rotating, as this may leave unwanted marks on the floor.
4. To collect light and bulky waste materials, lift the front blade by pressing the flap pedal (F, Figure 8); take into consideration that the machine vacuum capability is reduced when the front blade is lifted.



Notes!

When operating on wet surfaces, press the dust fan button (A, Figure 10) to turn off the vacuum system to prevent damage to the dust filter.

5. For the machine to operate properly, the filter must be kept as clean as possible. Press the filter shaker button (B, Figure 10) to activate the dust shaking function. During this process, the vacuum motor will automatically turn off. After dust shaking, the vacuum system will automatically resume operation and then continue cleaning. During operation, press the filter shaker button (B, Figure 10) for 2 seconds to start the "Automatic Filter Dust Shaking" mode, which repeats the automatic dust shaking process every 10 minutes on average (the repetition interval can be modified in settings, and users can adjust it based on the dust level in the cleaning area).



Note!

This process can also be performed while the machine is moving.



Note!

The machine cannot collect dust and debris if the filter is clogged or the hopper is full.

6. The hopper (D, Figure 11) should be emptied after each working cycle and when it is full (see the next section).

Hopper

1. Stop the machine (see the previous sections for the procedure).
2. Engage the parking brake.
3. Disengage the latch (A, Figure 11) by pulling its lower end.
4. Remove the hopper by disengaging it from the inner guides with the handle (B, Figure 11).
5. Discharge all the debris into special containers. To make discharging procedure easier, there is an inner box with handle (C, Figure 11) inside the hopper.
6. Install the hopper (D, Figure 11), and engage it into the internal guides.
7. Fasten the latch (A, Figure 11). The machine is now ready to start cleaning again.

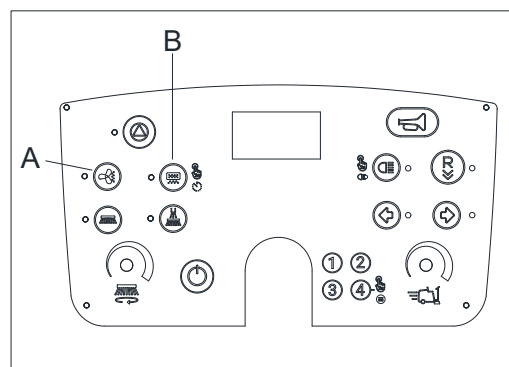

Figure 10

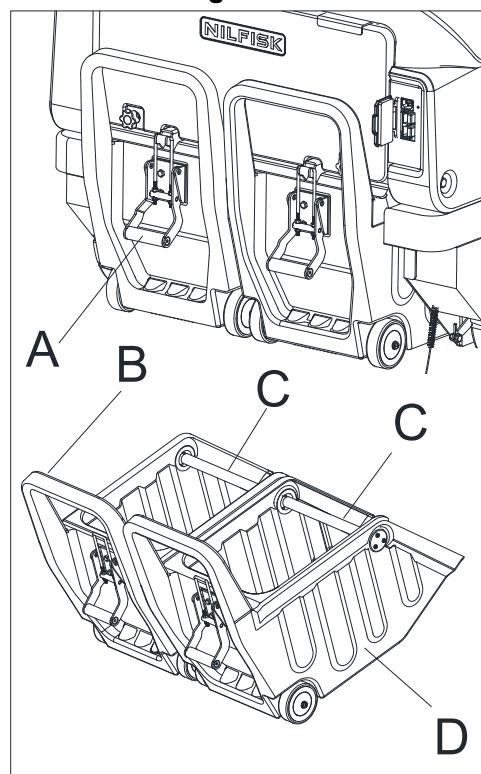

Figure 11

Side Broom Installation

1. Drive the machine onto level ground and press the parking pedal to park the machine.
2. Press the power button to turn off the machine.
3. Release the spring on the "D" pin (A, Figure 12), then remove the "D" pin from the side broom shaft (B, Figure 12).
4. Place the new side broom on the side broom motor shaft, align the holes on the side broom hub with the hole on the motor shaft (D, Figure 12), then insert the "D" pin (B, Figure 12) and finally fasten the spring (A, Figure 12).
5. Adjust the side broom height as described earlier.

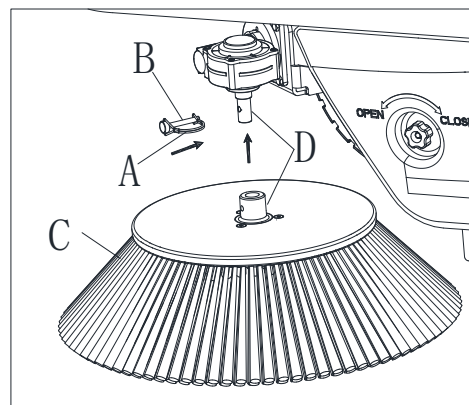

Figure 12

Spray Flow Setting

The machine settings are as follows:

1. Press the power button (A, Figure 13).
2. Use the 4-digit pin pad (C, Figure 13) to enter the password. The default password is 1234.
3. After successfully logging in, press and hold ④ button (D, Figure 13) for 2 seconds to enter the MENU interface (K, Figure 13).
4. In the MENU interface, press ① button (B, Figure 13) to go back to the previous menu, press indicator left button (G, Figure 13) to scroll down, press indicator right button (F, Figure 13) to scroll up, select "SETTINGS", then press ② button (E, Figure 13) to confirm the selection and enter the SETTINGS interface (J, Figure 13).
5. In the SETTINGS interface (J, Figure 13), select (I, Figure 13) WATER SPRAY to enter the WATER SPRAY settings interface (H, Figure 13).
6. Press indicator left button (G, Figure 13) to decrease the spray speed, press indicator right (F, Figure 13) to increase the spray speed, and adjust to the desired setting, then press ② button (E, Figure 13) to update the change.

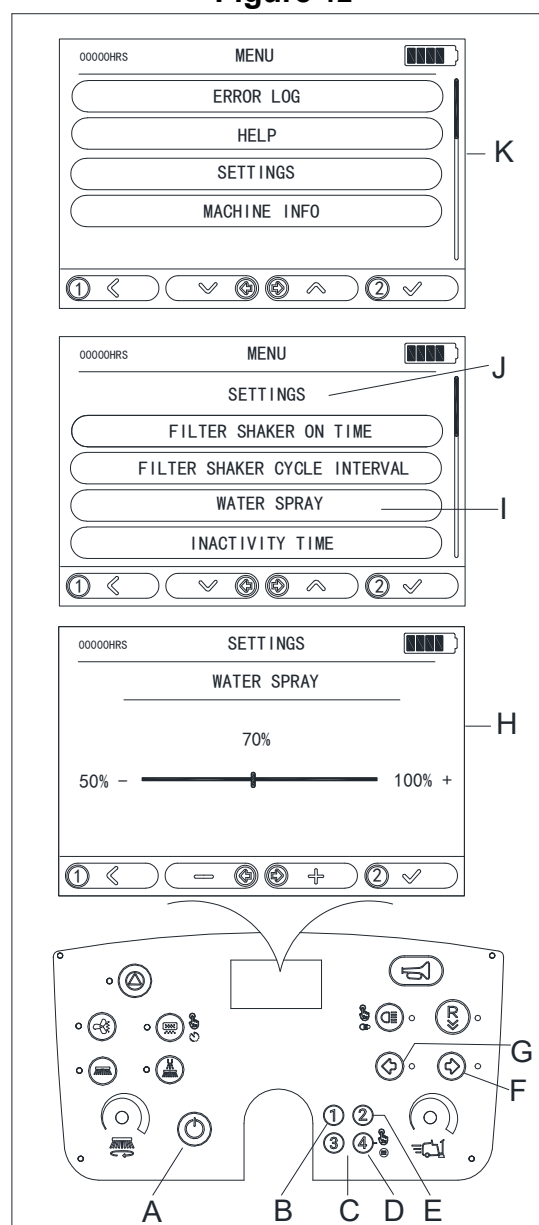

Figure 13

After Using the Machine

Once the cleaning work is completed, please follow these steps before leaving the machine:

1. Press the start button (C, Figure 14) to disable all cleaning motor functions (dust fan, side broom/main broom), and the side broom and main broom will be lifted.
2. Press the filter shaker button (B, Figure 14) to activate the dust shaking function and clean the filter.
3. Empty the hopper (D, Figure 11) (see the previous section for the steps).
4. Press the power button (A, Figure 14) to turn off the power.
5. Press the brake to park the machine.
6. If needed, charge the battery (refer to the maintenance section for the operating steps).
7. Complete the daily maintenance steps (refer to the maintenance section).
8. Store the machine in a dry and clean place.

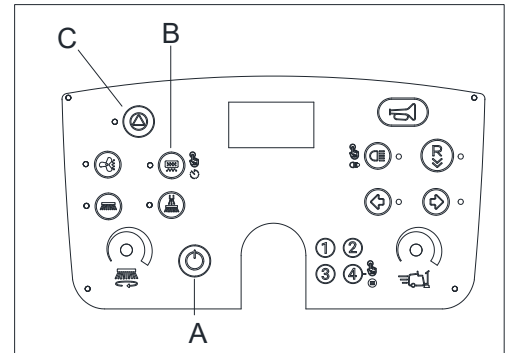

Figure 14

Towing/Pushing the Machine

Turn off the machine. To tow or push the machine, follow these steps:

1. Open the cover (A, Figure 15).
2. Pull the handle (B, Figure 15) of the drive motor outward.
3. Insert a screwdriver (C, Figure 15) into the slot (D, Figure 15). Close the cover, and then the machine can be pushed or towed.
4. When the machine reaches its destination, remove the screwdriver (C, Figure 15), and the machine will be able to operate normally.

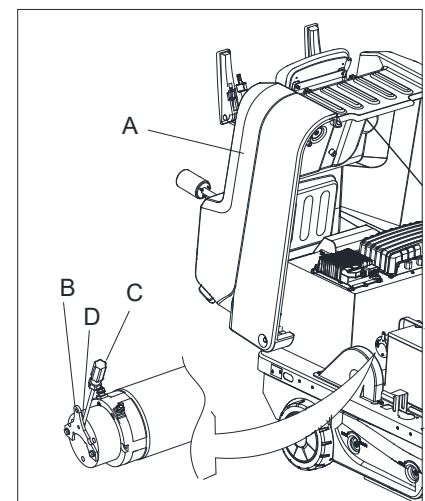

Figure 15

Long-Term Storage

If the machine will not be used for more than 30 days, please handle it as follows:

1. Complete all steps for "After machine use."
2. Disconnect the battery connector.
3. To avoid damage to the battery, if the machine is not used for more than 3 months, charge the battery every 3 months.

First Use

After the first 8 hours of use, check if any fasteners or connections are loose and check for visible damage or leaks.

Maintenance



Warning!

Maintenance procedures must be performed after the machine is turned off and the battery charger cable is disconnected. Before performing any maintenance steps, please carefully read the safety sections in the manual.

All scheduled or extraordinary maintenance procedures must be performed by qualified personnel or an authorized Service Center. This manual only describes the general and common maintenance procedures. For other maintenance procedures that are not in below maintenance schedule table, please contact our Technical Support Department.

Scheduled Maintenance Table

Procedure	After Delivery	Every 10 Hours	Every 50 Hours	Every 100 Hours	Every 200 Hours	Every 400 Hours
Battery charging	(1)					
Battery (WET) electrolyte level check		(2)				
Main broom cleaning						
Side and main broom height check and adjustment						
Dust filter cleaning and integrity check		(3)				
Blade height and operation check						
Filter shaker operation check			(*)			
Main broom drive belt visual inspection			(*)			
Flap pedal check and adjustment				(*) (4)		
Steering chain check and cleaning					(*)	
Main broom drive belt replacement					(*)	
Main broom motor and drive system motor carbon brushes check or replacement						(*)

(*) For related procedures, refer to the *Service Manual*.

1. Daily or after using the machine.
2. Before starting the machine.
3. Or more frequently in dusty areas.
4. If used on slopes, the maintenance frequency should be increased.

Battery Charging



Note
Please charge the battery when the battery level is low.



Caution!
Keeping the battery charged can extend its lifespan.



Caution!
Charge the battery as soon as it runs low, as failure to do so may shorten the battery's lifespan. Check the battery level at least once a week.



Warning!
During charging, wet-cell batteries emit flammable hydrogen gas. Ensure the charging area is well-ventilated and away from open flames. When charging, open the wastewater tank and avoid smoking near the charging battery accessories.



Warning!
Exercise special caution when charging the battery, as there may be leakage of acidic liquid during the charging process. Battery acid is corrosive. If accidentally contact with skin or eyes, rinse immediately with a large amount of water and seek medical attention. Do not operate the machine during the charging process.

Preparation steps

1. Drive the machine to the designated charging area.
2. Press the power button to turn off the machine (B, Figure 16).
3. Follow the steps below to charge the battery.

Battery charging (using an external charger)

4. Open the charging port protective cover (C, Figure 16). Connect the external charger's connector to the DC charging port on the machine (E, Figure 16). When the external charger is connected to the machine, all functions on the machine will automatically shut down.
5. Plug the AC power cord of the charger into the socket.
6. When charging is complete, first disconnect the charger from the power source, then disconnect it from the machine.
7. After charging is complete, check the battery electrolyte level (only for WET type batteries).
8. Press the power button to turn on the machine (B, Figure 16) and check the battery status on the panel display (A1, Figure 16).

Battery charging (using the on-board charger)

9. Open the charging port protective cover (C, Figure 16). Connect the power cable to the on-board charging port on the machine (D, Figure 16), then plug the other end of the power cable into the socket.
10. The battery charging status can be viewed on the LCD display (A2, Figure 16).
11. When charging is complete, unplug the power cable from the socket, then disconnect the power cable from the machine.
12. Check the battery electrolyte level (only for WET batteries).
13. Press the power button to turn on the machine (B, Figure 16) and check the battery status on the panel display (A1, Figure 16).

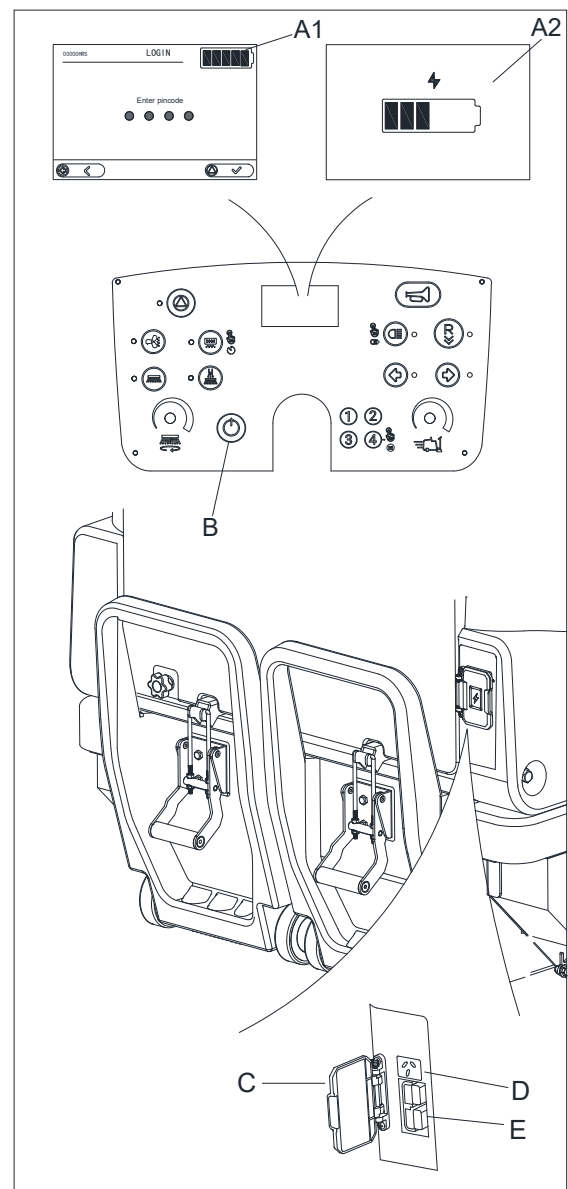

Figure 16

Checking and Adjusting the Main Broom Height

i Note

The following method applies to all types of bristles.

- To check the height of the main broom from the ground, follow these steps:
 1. Drive the machine onto a level ground.
 2. Minimize the driving speed using the speed adjustment knob (A, Figure 17).
 3. Press the start button (B, Figure 17) and press the accelerator pedal to turn on the main broom for about 1 minute.
 4. Press the start button again to stop the main broom and lift it.
 5. Check the width of the broom print on the ground (A, Figure 18), which should be between 2 and 4 cm.
 6. If the width of the broom print (A, Figure 18) is not within specifications, adjust the main broom height using the following steps.
 - Rotate the knob (B, Figure 19) as follows:
 7. To increase the print width, rotate the knob counterclockwise to lower the main broom.
 8. To decrease the print width, rotate the knob clockwise to lift the main broom.

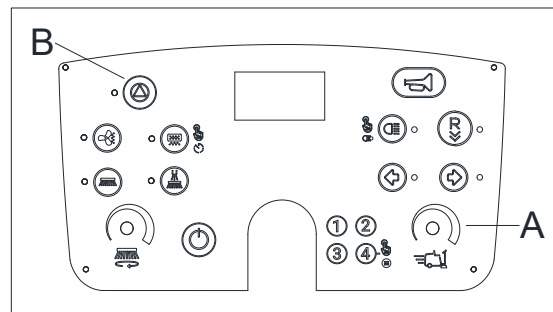

Figure 17

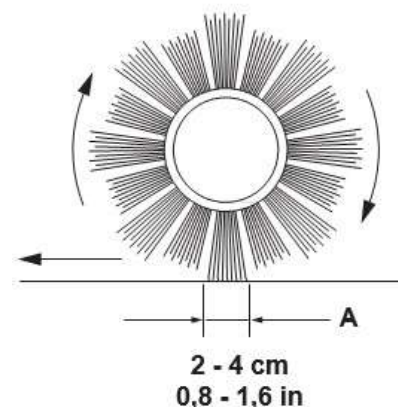

Figure 18

i Note

The broom height can be adjusted according to bristle wear of the broom to make sure the print is within specifications.

- Check the distance between the main broom and the ground by following the above steps to ensure it is appropriate.
- When the main broom is too worn to be adjusted, please follow the steps below to replace it.

i **Caution**

If the print (A, Figure 18) cannot be adjusted properly due to different length of bristles resulting in different pressure on the floor, refer to the Service Manual.

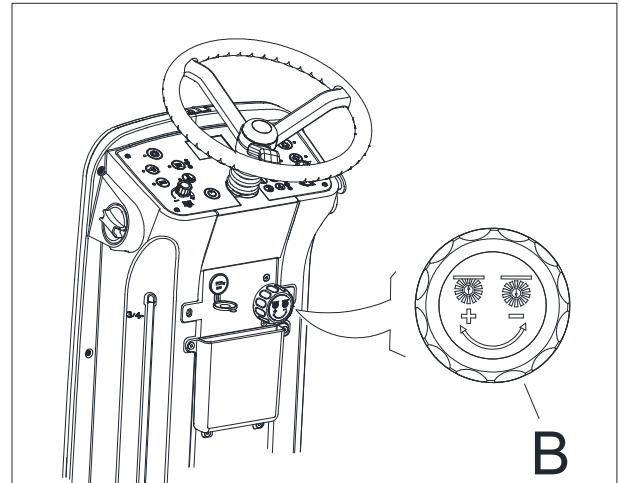

Figure 19

Replacing the Main Broom



Warning!

When replacing the main broom, it is recommended to wear protective gloves, as sharp debris may be trapped between the bristles of the broom.

1. Drive the machine onto a level ground and press the parking pedal.
2. Press the power button (B, Figure 16) to turn off the power.
3. Unscrew the two knob nuts (A, Figure 20) and remove the left cover (B, Figure 20).
4. Unscrew the knob bolt (A, Figure 21, hold (B, Figure 23), and remove the left bracket assembly of the main broom (C, Figure 23).
5. Remove the main broom (E, Figure 22).
6. Check if there is dust or other foreign objects (such as wires, fabric, etc.) on the drive hub (F, Figure 22). If so, clean them off.
7. When installing a new main broom, ensure the bristle shape is as shown in (G, Figure 22).
8. When installing a new main broom, align the main broom hub (H, Figure 22) with the drive hub (F, Figure 22).
9. Install the driven hub (D, Figure 23) onto the main broom.
10. Install the left bracket assembly of the main broom (C, Figure 23) and tighten the knob bolt (A, Figure 21).
11. Install the left cover (B, Figure 20) and tighten the two knob nuts (A, Figure 20).
12. As shown in the previous section, check and adjust the main broom height.

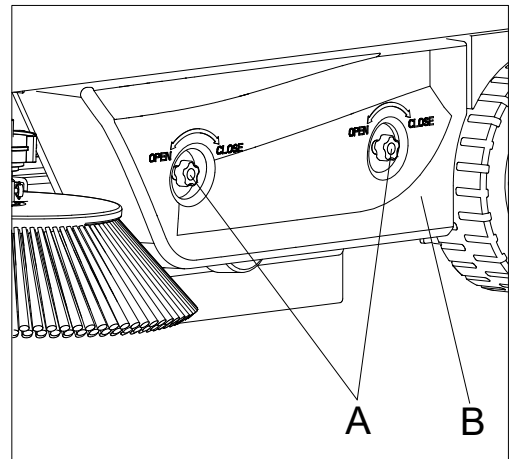

Figure 20

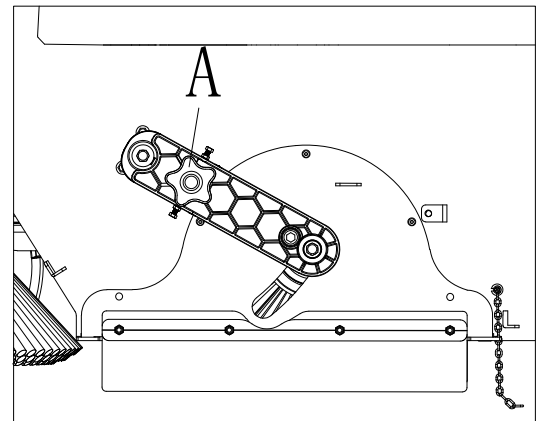

Figure 21

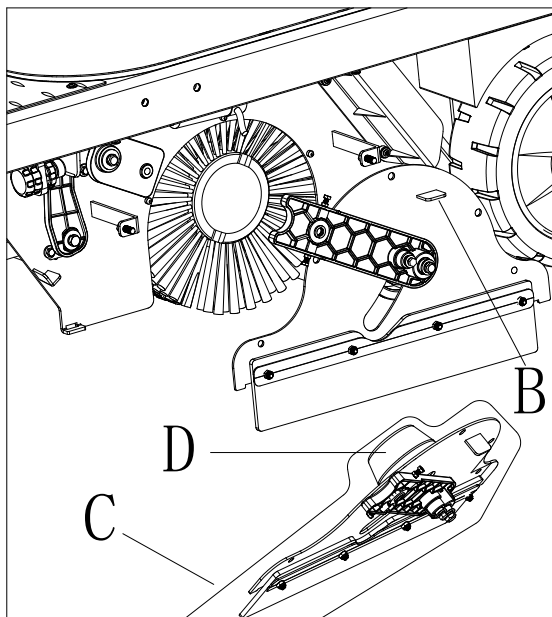

Figure 23

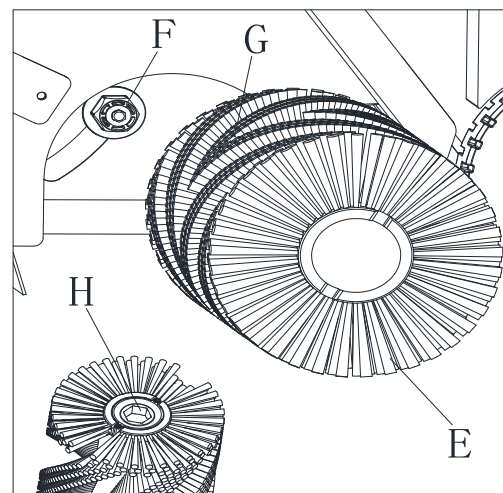

Figure 22

Checking and adjusting the side broom height



Caution

The main broom is available with both hard and soft bristles.

The following method applies to all types of bristles.

- Follow the steps below to check the height of the side brooms from the ground:
- Drive the machine onto a level ground.
- Adjust the speed to the minimum using the machine speed dial (A, Figure 24).
- Press the start button (D, Figure 24) to enable cleaning.
- Press the side broom button (B, Figure 24) to lower the side broom to working height, press the accelerator pedal, and let the side broom run for 1 minute.

Check if the side broom print (A and B, Figure 25) matches the specifications (A and B, Figure 25).

As shown.

If the broom print does not meet the specifications, follow the steps below to adjust the side broom height.

1. Press the parking pedal.
2. Press the power button (C, Figure 24) to turn off the power.
3. Unscrew the two knob nuts (A, Figure 20) and remove the left cover (B, Figure 20).
4. First, unscrew the knob nut (D, Figure 26), then adjust the height of the side broom by turning the adjustment knob (C, Figure 26) until the side broom print matches the illustration (A and B, Figure 25). After adjustment, tighten the knob nut (D, Figure 26).
5. When the side broom bristles have worn after use, follow the above steps to adjust the side broom to the proper height.
6. When the side broom bristles are excessively worn and cannot be adjusted, please follow the steps below to replace the side broom.

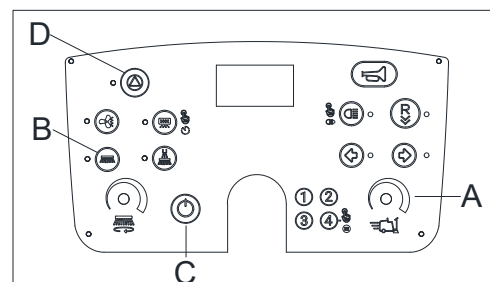

Figure 24

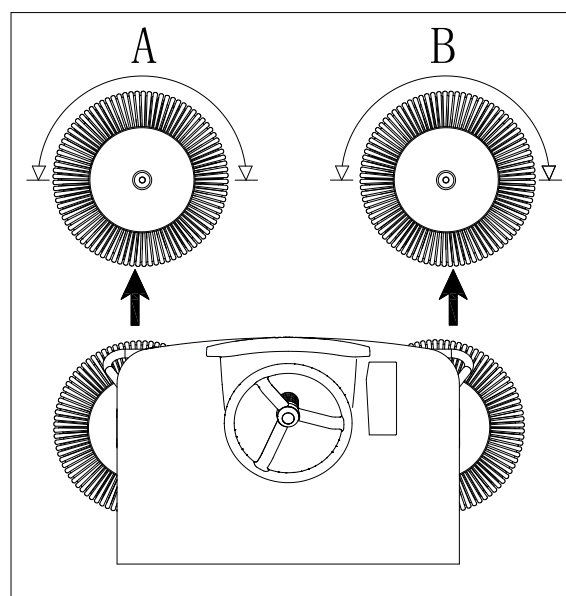

Figure 25

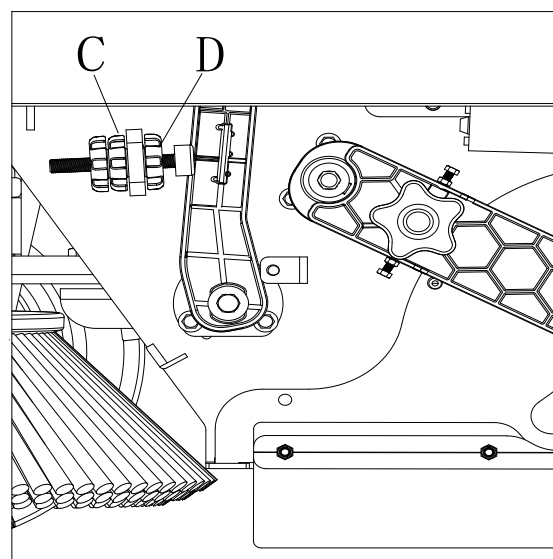

Figure 26

Cleaning and Replacing the Dust Filter

Caution

In addition to the standard polyester filter, paper filters are also available. The following cleaning and replacement methods apply to both types of filters.

1. Drive the machine onto a level ground and press the parking pedal.
2. Press the power button (C, Figure 24) to turn off the power.
3. Lower the cover (A, Figure 27).
4. Open the hopper zipper using the handle (F, Figure 27).
5. Use the hopper handle (C, Figure 27) to remove the hopper (E, Figure 27).
6. Loosen the screw (D, Figure 27) to remove the hopper cover plate (B, Figure 27).
7. Loosen the nut (A, Figure 28).
8. Disconnect the vibration motor wiring (B, Figure 28) from the connector (C, Figure 28).
9. Remove the dust shaking plate (D, Figure 28).
10. Take out the filter (E, Figure 28).
11. Clean the filter on a level, clean surface. Gently tap the side (A, Figure 29) opposite the wire mesh side (B, Figure 29). Use compressed air with no more than 6 psi pressure to clean, blowing air from the side with the wire mesh (B, Figure 29) at least 30 cm away from the filter. Depending on the type of filter, please pay attention to the following:
 - Paper filter (optional): Do not clean with water or detergent, as it will damage the filter.
 - Polyester filters (standard): For better cleaning, you can use water and non-foaming detergent. This cleaning method will improve filter cleanliness but may shorten the filter's lifespan, requiring more frequent replacements. Improper use of detergent may damage the filter.
12. Check the filter for any cracks. If necessary, replace the filter.
13. Clean the rubber strip on the cover plate (F, Figure 28) and check for damage or cracks. If damaged, replace it.
14. Assemble in the reverse order of disassembly and pay attention to the following:
 - When installing the filter (E, Figure 28), the side with the wire mesh (B, Figure 29) should face upward.

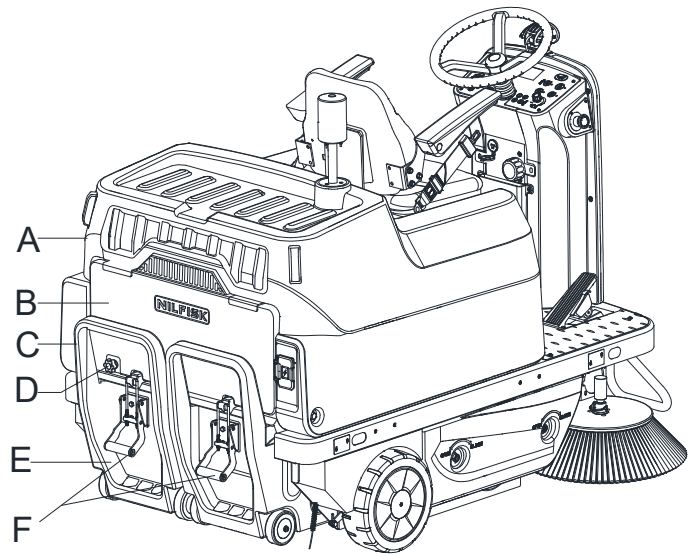

Figure 27

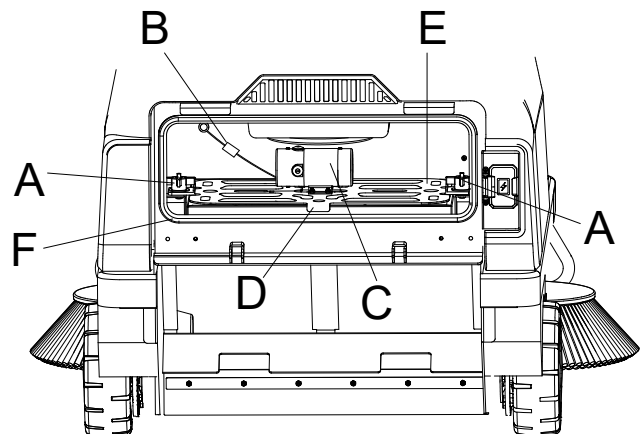

Figure 28

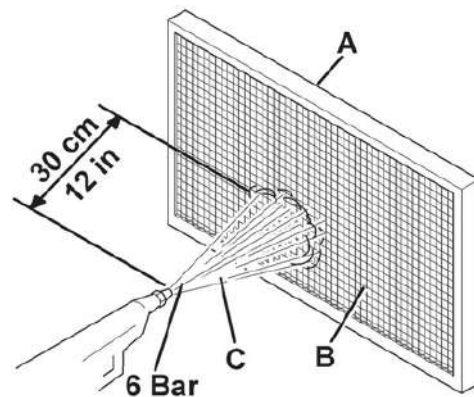

Figure 29

Checking and Replacing the Blade

1. Drive the machine onto a level ground.
2. Press the parking pedal.
3. Ensure the machine is powered off.

Side Blade Inspection

4. Unscrew the nuts (A and D, Figure 30) and remove the left (B, Figure 30) and right covers (E, Figure 30).
5. Check if the side blades (C and F, Figure 30) are intact. If there is a cut longer than 20mm (A, Figure 31) or a crack longer than 10mm (B, Figure 31), please replace the blade (refer to the service manual for blade replacement).
6. Check that the distance from the ground to the side blade (C, F, Figure 30) is within 0-3mm (A, Figure 31). If necessary, adjust the blade height by adjusting the threads on the screws (A, Figure 32).
7. Assemble in the reverse order of disassembly.

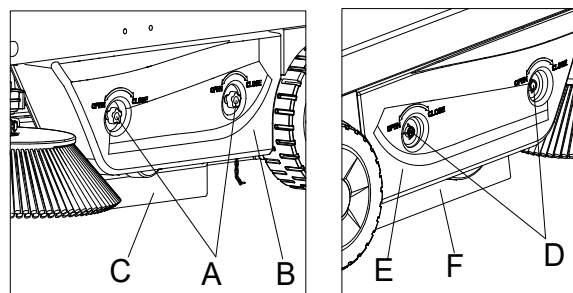

Figure 30

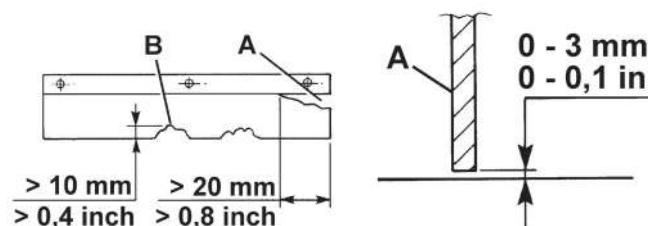

Figure 31

Checking the Front and Rear Blade

8. Remove the main broom as shown in the relevant section.
9. Check if the front blade (A, Figure 35) and rear blade (B, Figure 34) are intact. If there is a cut longer than 20mm (A, Figure 31) or a crack longer than 10mm (B, Figure 31), please replace the blade (refer to the service manual for blade replacement).
10. Inspection standard:
 - The front blade (A, Figure 35) should lightly touch the bottom surface (A, Figure 31).
 - The distance from the ground to the rear blade should be 0.3 mm (A, Figure 31).
11. If necessary, you can adjust the height of the front and rear blades by turning the screws (C and D, Figure 35 and Figure 34).
12. Press the front blade lift pedal and check if the front blade (A, Figure 31) is lifted. Then release the lift pedal and check if the front blade returns to its original position. If necessary, adjust or replace the front blade (refer to the *Maintenance Manual*).
13. Assemble in the reverse order of disassembly.

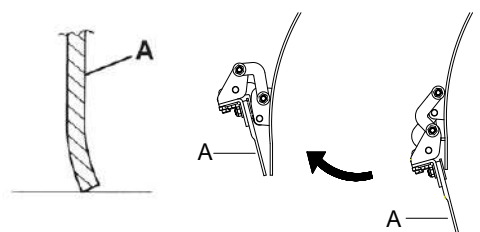

Figure 32

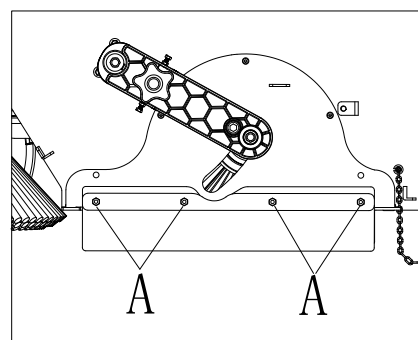

Figure 33

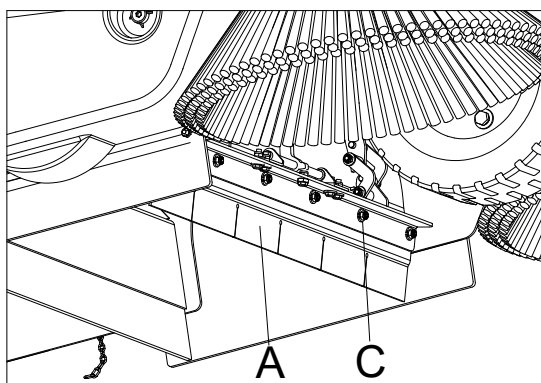

Figure 35

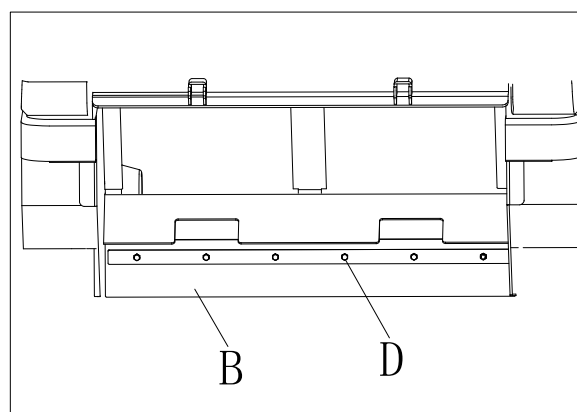

Figure 34

Chain Tension Check and Adjustment

1. Drive the machine onto a level ground.
2. Press the parking pedal.
3. Ensure the machine is powered off.
4. If the front wheel chain is loose, adjust the chain adjustment screw (A, Figure 36) from the front underside of the machine to ensure the chain has the appropriate tension.
5. If the rear wheel chain is loose:
6. Open the cover (C, Figure 37).
7. Remove the chain protection cover (A, Figure 37).
8. Adjust the chain adjustment screw (B, Figure 37) to ensure the chain has the appropriate tension.

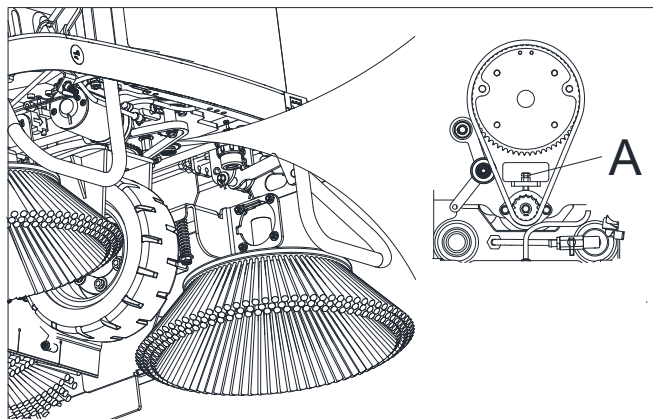

Figure 36

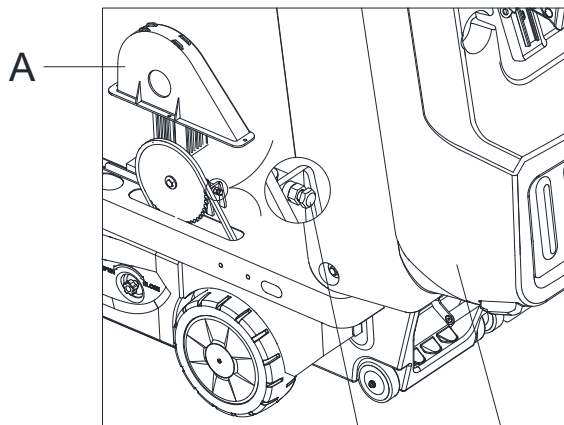

Figure 37

Troubleshooting

Symptom	Possible Cause	Solution
If the machine cannot start after pressing the power button.	The battery connector is not properly inserted.	Insert the battery connector properly.
	The ports for EB1 Main controller (P6) and EB3 UI controller (J1) are not properly connected.	Ensure the connections are correct.
	Battery level is too low.	Charge the battery.
The machine does not move when the accelerator pedal is pressed.	The brake pedal is pressed and locked.	Release the brake pedal.
	Successfully log in while pressing the accelerator pedal.	The operator should sit in the seat, ensuring their feet are not pressing the accelerator pedal, then start the machine and log in.
	The operator is not seated or is seated incorrectly.	The operator should sit in the seat, adjust their position, and sit correctly.
	Battery level is too low.	Charge the battery.
The main broom is not working.	The fuse is faulty.	Replace the fuse with one of the same specifications.
	The start button has not been pressed.	Press the start button to enable the cleaning mode.
The side broom is not working.	The side broom button or start button has not been pressed.	First press the start button to enable cleaning mode, then press the side broom button to enable the side broom function.
	The fuse is faulty.	Replace the fuse with one of the same specifications.
No water is coming out of the nozzle	No water in the water tank	Add water to the water tank
	Side broom function is not turned on	First press the start button to enable cleaning mode, then press the side broom button to enable the side broom function.
	Float switch connection fail.	After adding water and turn on side broom, if the LCD still indicates no water in the tank, check the connection of float switch.
	Float switch is damaged.	Replace the float switch.
	The water pump is damaged	Replace the water pump
The machine's garbage/dust collection function is missing or degraded	The dust fan is not turned on	Turn on the dust fan
	The fuse is faulty.	Replace the fuse with one of the same specifications.
	The filter is clogged	Activate the filter shaker to clean the filter, or remove the filter for cleaning
	The hopper is full	Empty the hopper
	Blade adjustment is inappropriate or worn	Adjust or replace the blade
	The broom disk is not adjusted to the proper position	Adjust the broom disk to the proper height
The filter shaker is not working	The fuse is faulty.	Replace the fuse with one of the same specifications.

Cleaning mode disabled	Battery level is low.	Charge the battery. If the fault persists, replace the battery
Battery performance is unreliable.	The battery is damaged.	Replace the battery.
	Battery capacity is low.	Replace with a higher capacity battery. (Please refer to the technical data section.)

Destruction

Have a qualified waste disposal organization handle the disposal of the scrapped machine.

Before destroying the machine, please remove and isolate the following materials, which must be properly disposed of according to relevant laws and regulations.

- Battery
- Broom disk
- Plastic hoses and plastic components
- Electrical and electronic components (*)

(*) If electrical and electronic components need to be destroyed, please contact our service center.

Material composition and recyclability

Type	Recyclable Materials (%) Percentage	Weight (%)
Aluminum alloy	100%	1%
Motor	29%	20%
Iron	100%	39%
Wire	80%	1%
Liquid	100%	0%
Non-recyclable plastic	0%	0%
Recyclable plastic	100%	35%
Rubber	20%	3%